



Uniden®

ATLANTIS 250
Owner's Manual



OWNER'S MANUAL





Contents

Controls and Indicators	2
LCD display	3
Warning!	4
Ni-MH Battery Pack Warning	4
Introduction	5
Features	5
Technical Support and Service	6
Included in Your Package	7
Getting Started	8
Mounting the Cradle	8
Attaching the Antenna	8
Attaching the Rechargeable Battery Pack	8
Using the Alkaline Battery Case	9
Attaching the Beltclip	9
Charging the Battery Pack	10
Operation	11
Turning On the Unit and Setting Squelch	11
Selecting a Channel	12
One-touch Channel 16/9	12
Triple Watch	13
Programming a Channel into Memory	14
Deleting a Channel from Memory	15
Scanning	15
Transmitting	16
Lighted Keys and Display	16
Turning and reactivating the Key Beep	16
Battery Indicator	17
Key Lock	17
Marine Channels - International	18
Optional Parts and Replacement Accessories	20
Specifications	21
Troubleshooting	22
Warranty	23





Controls and Indicators

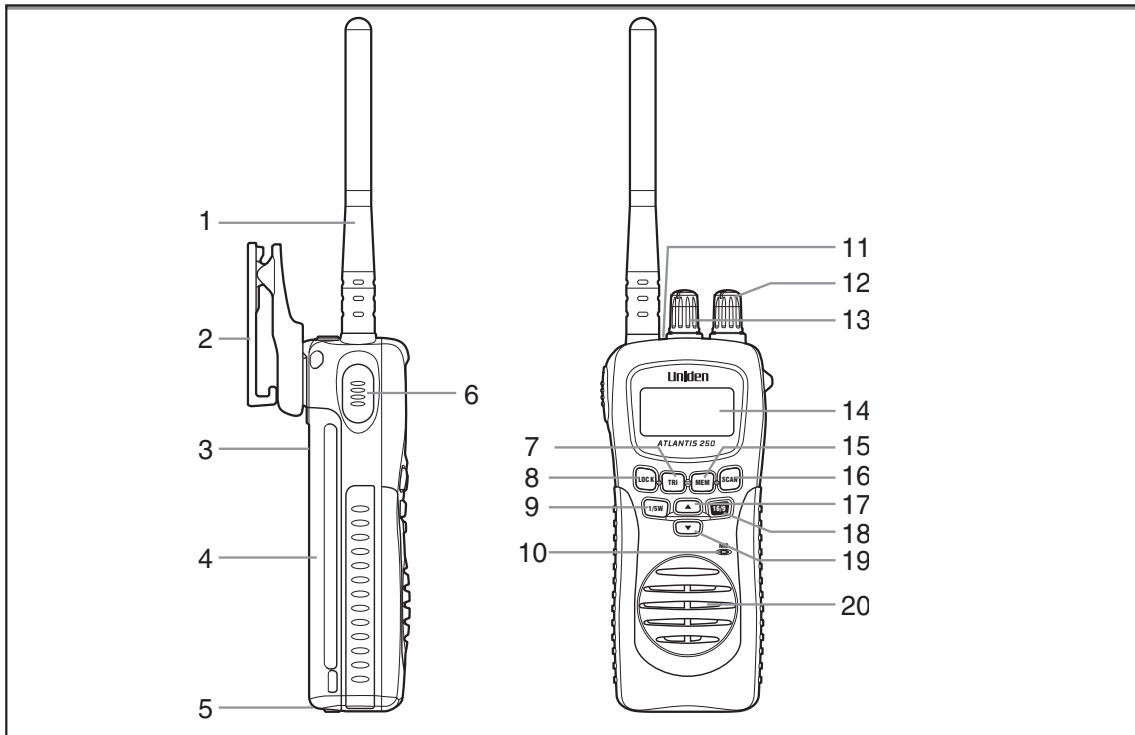

- 1 Antenna
- 2 Belt Clip
- 3 Adaptor Jack
- 4 Battery
- 5 Battery Release Clip
- 6 PTT (Push to Talk) Key
- 7 Triple Watch Button (TRI)
- 8 Lock Button (LOCK)
- 9 TX Power Button (1/5W)
- 10 Microphone
- 11 Speaker MIC (Optional) Jack
- 12 Volume/Power Knob (VOL)
- 13 Squelch Knob (SQ)
- 14 LCD Display
- 15 Memory Button (MEM)
- 16 Scan Button (SCAN)
- 17 Channel Up Button (▲)
- 18 16/9 Button (16/9)
- 19 Channel Down Button (▼)
- 20 Speaker



LCD Display

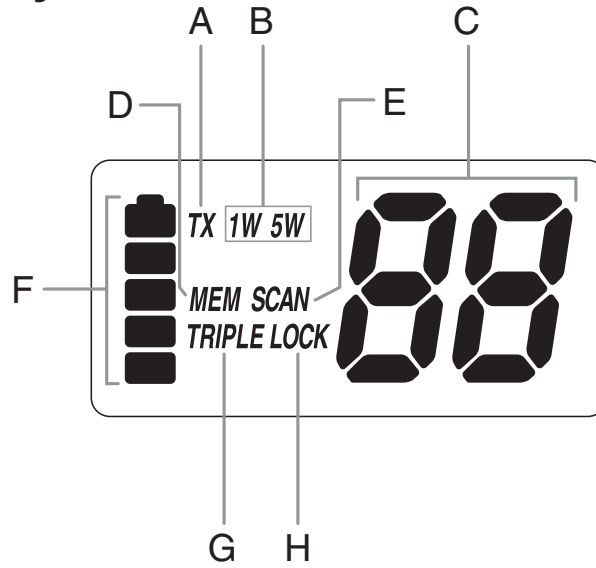

- A Transmit Indicator
- B TX Power Indicator
- C Channel Number Display
- D Memory Indicator
- E Scan Indicator
- F Battery Indicator
- G Triple Watch Indicator
- H Key Lock Indicator



Warning!

- The **ATLANTIS 250** is splashproof only when the antenna, rubber caps (adaptor jack and speaker mic jack) and the battery are properly attached.
- Do not operate the transmitter of any radio equipment unless all the Radio Frequency (RF) connectors are secure and any open connectors are properly terminated.
- Do not operate the transmitter of any radio equipment near electrical blasting caps or in an explosive atmosphere.
- Do not let children operate any transmitter-equipped radio equipment without proper supervision.
- Have your radio equipment serviced by a qualified technician.
- Do not operate the transmitter of any radio equipment with the antenna touching or close to the eyes, face, or exposed body parts.



Ni-MH Battery Pack Warning



- This equipment contains a Ni-MH Battery Pack.
- The Ni-MH Battery Pack contained in this equipment may explode if disposed of in a fire.
- Do not short-circuit the Battery Pack.
- Do not charge the Ni-MH Battery Pack used in this equipment with any Adaptor other than the one designed to charge this Battery Pack. Using another Adaptor may damage the Battery Pack or cause the Battery Pack to explode.
- Ni-MH batteries must be disposed of properly.



The exclamation point within an equilateral triangle is intended to alert the user to the presence of important operating and maintenance (servicing) instructions in the literature accompanying the appliance.





Introduction

The **ATLANTIS 250** is a splashproof, portable two-way VHF transceiver. It is compact, lightweight, rugged and fits easily in your hand.

This handheld VHF marine radio will give you consistent, outstanding performance in virtually all conditions and situations.

To ensure that you get the most from the **ATLANTIS 250's** features, please read this operating guide carefully before using the unit.

Features

- Splashproof (meets JIS4 splashproof specifications)
- Triple Watch Mode
- Programmable Memory
- One-Touch Channel 16/9
- Memory Scan
- Table-Top Cradle (can also be wall-mounted)
- Rechargeable Ni-MH Battery Pack
- Battery Save Operation
- Key Lock
- Back-Lit Keys and Display
- Belt Clip
- Wrist Strap
- TX Power 1W/5W
- Alkaline Battery Case (Alkaline batteries are not included)





Technical Support and Service

Your Uniden dealer can provide you with sales assistance and information. If your marine radio does not perform properly, follow the troubleshooting tips in the back of this operating guide.

The radio contains no user-serviceable parts. Unauthorized adjustment will cause illegal radio operation.

Be sure that a qualified technician services your radio equipment.

Caution: Changes or modifications to this product not expressly approved by Uniden, or operation of this product in any way other than as detailed by this Operating Guide, can void your authority to operate this product.





Included in Your Package



ATLANTIS 250

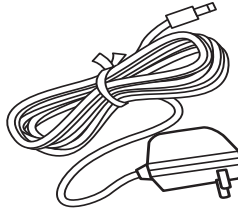

AC Adaptor

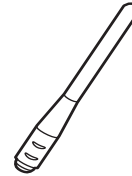

Antenna

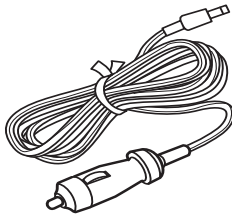

DC Adaptor

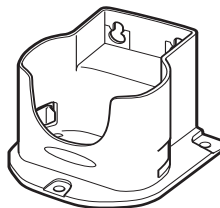

Cradle

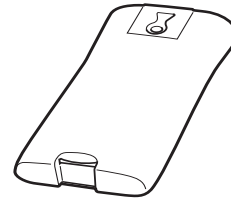

Rechargeable Battery

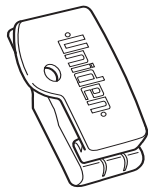

Beltclip



Wrist Strap



Mounting Screws

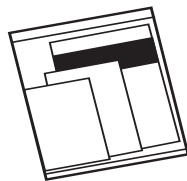

Owner's Manual/
Printed Material

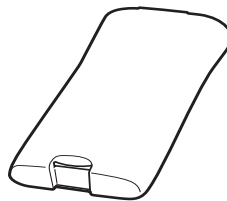

Alkaline Battery Case
(attached to the ATLANTIS 250)





Getting Started

Mounting the Cradle

Mount the Cradle to either a counter or wall.

To counter:

Attach the Cradle using the mounting screws and washers as follows.

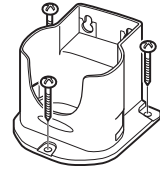

To wall:

Apply the Cradle to the wall and insert the two mounting screws into the larger holes of the Cradle

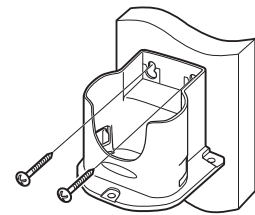

Push down the Cradle until it is firmly seated.

When you remove the Cradle from the wall, loosen the screws and push the Cradle up.

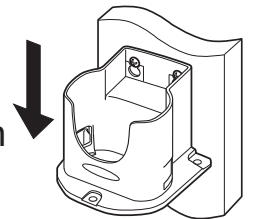

Attaching the Antenna

Apply the antenna to the radio as shown. Be sure the antenna is firmly seated.



Attaching the Rechargeable Battery Pack

- 1** Snap the battery release clip out and remove the alkaline battery case. Then place the rechargeable battery pack onto the back of the radio. It will only fit in one way.
- 2** Snap the battery release clip until it clicks. Be sure the battery pack fits tightly against the body.

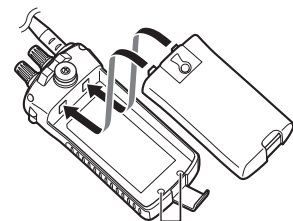

Contacts

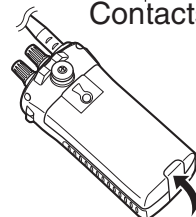

Using the Alkaline Battery Case

When needed, you can use the battery case with AA Alkaline batteries (not included) instead of the rechargeable battery pack.

To install the batteries:

- 1** Remove the battery case cover by pulling the 2 halves apart applying your fingers to the projections.
- 2** Install 6 AA Alkaline batteries (not included) into the battery case. Be certain to follow the + and - symbols in the compartment.

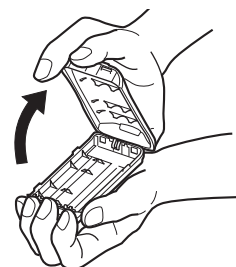

- 3** Replace the battery case cover as follows until it clicks into place.

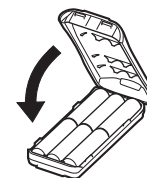

Attaching the Beltclip

- 1** Hold the beltclip in the direction as illustrated.
- 2** Apply it to the hanger piece on the back of the radio. Then slide it up.
- 3** When you hear a click, the beltclip is firmly attached.
- 4** To take the beltclip off the radio, turn it upside down and slide it up.

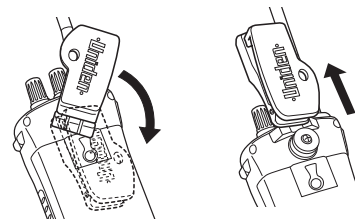
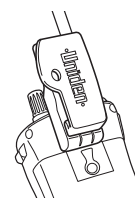
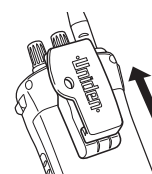

Charging the Battery Pack

Your marine radio is powered by a specially designed Ni-MH battery pack.

- Before operating the **ATLANTIS 250**, charge the Ni-MH battery pack for 16 hours without interruption with the Adaptor.

- 1** Place the **ATLANTIS 250** in the Cradle.

Make sure your radio is OFF.



- 2** Plug one end of the AC adaptor into the wall outlet and the other end into the Adaptor jack on the back of the **ATLANTIS 250**.

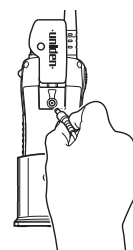

- 3** Charge the battery for 16 hours.



- The charger will not overcharge the battery pack. After 16 hours without interruption, charging is completed.
- **Be sure to replace the rubber cap after charging in order to secure the splashproof seal.**
- **The radio will not charge the battery while on and receiving incoming voice traffic.**
- When you mount the Cradle on your boat, use the DC adaptor instead.
- The jack is for charging only. If the battery level is low, the radio needs to be charged before use.



Operation

- See Controls and Indicators (page 2) for button, knob, and key positions.
- When you turn On your **ATLANTIS 250** just after purchasing, it is automatically tuned to channel 16 frequency for distress, safety, and calling.
- When you press any button (except PTT and LOCK key), a short tone sounds.

Turning On the Unit and Setting Squelch

- 1** Before you turn On the unit, turn the squelch (SQ) knob fully counterclockwise.

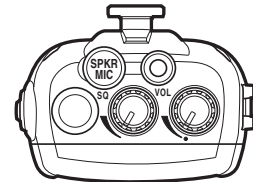

- 2** Then, turn On the unit by turning the Volume/Power (VOL) knob clockwise until you hear a hissing sound.

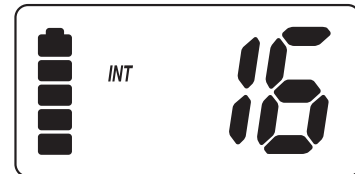

- 3** Turn the SQ knob clockwise, just until the hissing sound stops. Use the knob to adjust to the desired squelch level. Think of the squelch control as a frequency gate which controls access to weak or strong signals depending on its setting.

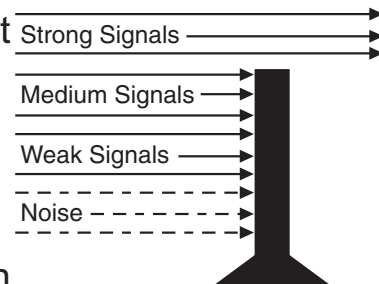

- To listen to a weak or distant station, turn the knob counterclockwise. If reception is poor, turn it clockwise to cut out weak transmissions.
- If the squelch control is adjusted so that you continually hear a hissing sound, the unit will not scan properly.

- 4** To turn Off the unit, turn the VOL knob counterclockwise until it clicks.



Selecting a Channel

1 Turn On your **ATLANTIS 250**.

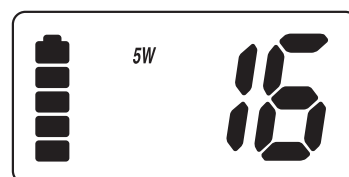

↓ [UP]

2 To select a higher channel, press the ▲ button.

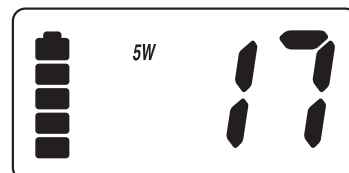

↓ [DOWN]

3 To select a lower channel, press the ▼ button.

- To change the channel continuously, press and hold the ▲ or ▼ button for more than 1 second.

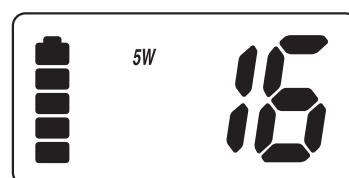

One-touch Channel 16/9

Example: While you are monitoring channel 20, you want to check channel 16 or channel 9.

1 You are now on channel 20.

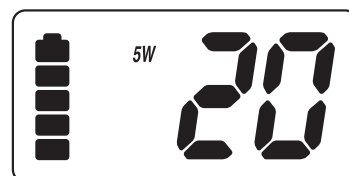

↓

2 To monitor channel 16, press the 16/9 button.

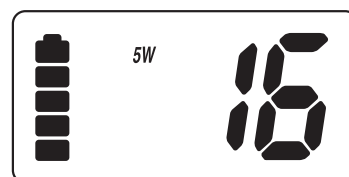

↓

3 To monitor channel 9, press the 16/9 button again.

4 To return to channel 20, press the 16/9 button again.

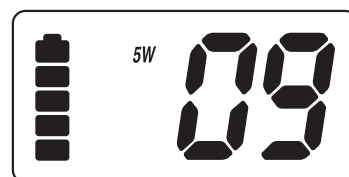

Triple Watch

Triple Watch mode monitors channels 16 and 9 for a signal while you listen to the currently selected channel. The marine radio checks channel 16 and 9 for activity every 2 seconds.

- 1** To select Triple Watch mode, press the TRI button. TRI PLE appears on the display.
- 2** To exit from Triple Watch, press the TRI button. TRI PLE disappears.
 - While in Triple Watch mode, you can change the currently selected channel using the ▲ or ▼ button.

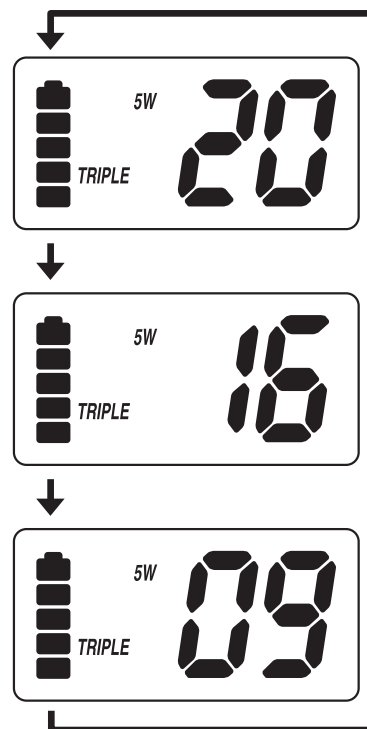

Programming a Channel into Memory

Before using the scanning feature, you have to program channels into memory.

- 1** Select the channel to enter into memory by pressing the ▲ or ▼ button.
- 2** Press the MEM button for two seconds to store the channel. MEM appears on the display.
- 3** Press shortly and successively the MEM button to move into the memorized channels.

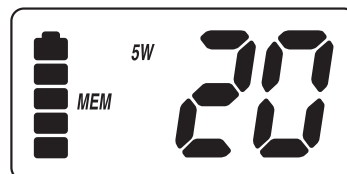

Deleting a Channel from Memory

- 1 Select the channel to delete from memory by pressing the ▲ or ▼ button.
- 2 Press the MEM button for two seconds. MEM disappears from the display.

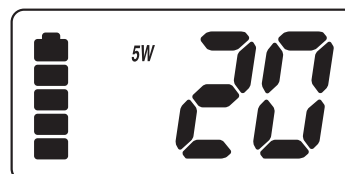

Scanning

- 1 To begin scanning the programmed channels, press the SCAN button. SCAN and TRI PLE appear on the display.
- 2 To stop scanning, press the SCAN button once more. SCAN and TRI PLE disappear from the display.

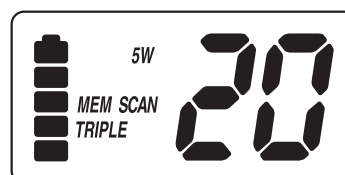

- Scanning starts from the lowest to highest channel and stops when it finds an active channel. It remains on that channel until the transmission ends, then resumes scanning after a 2 second delay period.
- When in the scan mode, the unit automatically activates the Triple Watch feature. To deactivate Triple Watch from the scanning mode, press TRI button. TRI PLE disappears from the display.

Transmitting

- 1 Transmission power can be set to either 5W or 1W.

Press the 1/5W button to make the change, then the 5W or the 1W indicator on the display changes accordingly.

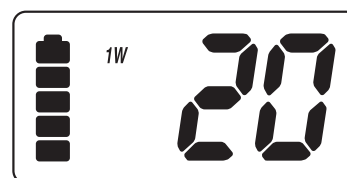

- 2 To transmit, press and hold the PTT (push-to-talk) key.
TX appears on the display.
- 3 To return to receive, release the PTT key.
TX disappears from the display.
 - If the PTT key is pressed for more than 5 minutes, TX starts blinking and the transmission ends. The TX time out tone will sound until the PTT key is released.
 - If the battery indicator drops to the blinking 1-mark level on the display and the PTT key is pressed, the radio will not transmit and the TX icon starts blinking. (Refer to the description of the Battery Indicator on the next page.)

Lighted Keys and Display

To light the display, press any key excluding the PTT key.

- If you press any button other than the PTT key while the display and keypad are illuminated, it remains illuminated for another 5 seconds.

Turning and reactivating the Key Beep

Your radio emits a beep each time one of the buttons (except for the PTT and LOCK key) is pressed.

To turn off or reactivate the Key beep:

Turn the radio on again while pressing and holding the ▲ or ▼ buttons.

Battery Indicator

When the unit is On, battery power is always indicated on the display.

When the battery is fully charged, the battery indicator appears as follows:

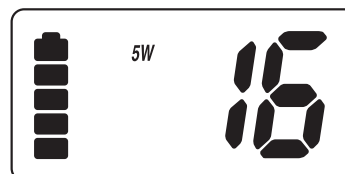

When the battery is nearly discharged, the battery indicator appears as follows:

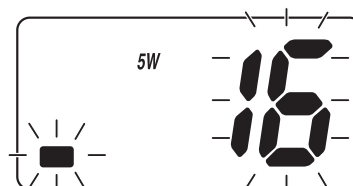

- When the battery indicator drops to the blinking 1-mark level on the display, the radio will receive but will not transmit.

Key Lock

To prevent accidental entries, you can lock the keypad.

- 1** Press and hold the LOCK button for 2 seconds. A double confirmation tone sounds. LOCK appears on the display.
 - 2** To unlock the keypad, press and hold the LOCK button again for 2 seconds. A double confirmation tone sounds. LOCK disappears from the display.
- You can also unlock the keypad by turning the radio Off and then On again.

Marine Channels - International

Channel Desig	Frequency (MHz)		Traffic Type	Ship to Ship	Ship to Shore	Permanent Scan List
	Transmit	Receive				
01	156.050	160.650	Duplex	Yes	Yes	
02	156.100	160.700	Duplex	Yes	Yes	
03	156.150	160.750	Duplex	Yes	Yes	
04	156.200	160.800	Duplex	Yes	Yes	
05	156.250	160.850	Duplex	Yes	Yes	
06	156.300	156.300		Yes	No	
07	156.350	160.950	Duplex	Yes	Yes	
08	156.400	156.400		Yes	No	
09	156.450	156.450		Yes	Yes	
10	156.500	156.500		Yes	Yes	
11	156.550	156.550		Yes	Yes	
12	156.600	156.600		No	Yes	
13	156.650	156.650		Yes	Yes	
14	156.700	156.700		Yes	Yes	
15	156.750	156.750		Yes	Yes	
16	156.800	156.800		Yes	Yes	
17	156.850	156.850		Yes	Yes	
18	156.900	161.500	Duplex	Yes	Yes	
19	156.950	161.550	Duplex	No	Yes	
20	157.000	161.600	Duplex	No	Yes	
21	157.050	161.650	Duplex	No	Yes	
22	157.100	161.700	Duplex	No	Yes	
23	157.150	161.750	Duplex	No	Yes	
24	157.200	161.800	Duplex	No	Yes	
25	157.250	161.850	Duplex	No	Yes	
26	157.300	161.900	Duplex	No	Yes	
27	157.350	161.950	Duplex	No	Yes	
28	157.400	162.000	Duplex	No	Yes	
60	156.025	160.625	Duplex			
61	156.075	160.675	Duplex			
62	156.125	160.725	Duplex			
63	156.175	160.775	Duplex			
64	156.225	160.825	Duplex			



Channel Desig	Frequency (MHz)		Traffic Type	Ship to Ship	Ship to Shore	Permanent Scan List
	Transmit	Receive				
65	156.275	160.875	Duplex	Yes	Yes	
66	156.325	160.925	Duplex	Yes	Yes	
67	156.375	156.375		Yes	No	
68	156.425	156.425		Yes	Yes	
69	156.475	156.475		Yes	Yes	
70	RX Only	156.525				
71	156.575	156.575		Yes	Yes	
72	156.625	156.625		Yes	No	
73	156.675	156.675		Yes	Yes	
74	156.725	156.725		Yes	Yes	
75	156.775	156.775		Yes	No	
76	156.825	156.825		Yes	No	
77	156.875	156.875		Yes	No	
78	156.925	161.525	Duplex	Yes	Yes	
79	156.975	161.575	Duplex	Yes	Yes	
80	157.025	161.625	Duplex	Yes	Yes	
81	157.075	161.675	Duplex	Yes	Yes	
82	157.125	161.725	Duplex	Yes	Yes	
83	157.175	161.775	Duplex	Yes	Yes	
84	157.225	161.825	Duplex	Yes	Yes	
85	157.275	161.875	Duplex	No	Yes	
86	157.325	161.925	Duplex	No	Yes	
87	157.375	157.375		No	Yes	
88	157.425	157.425		Yes	No	



Optional Parts and Replacement Accessories

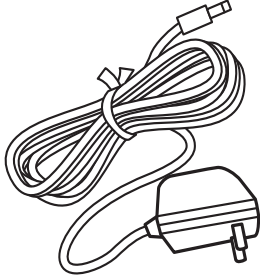

AC Adaptor



Mounting Screws

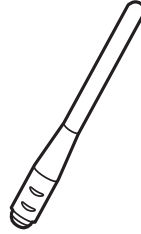

Antenna



Wrist Strap

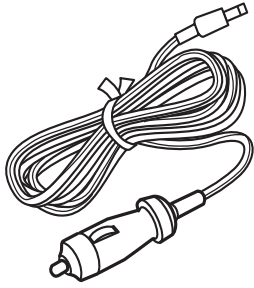

DC Adaptor

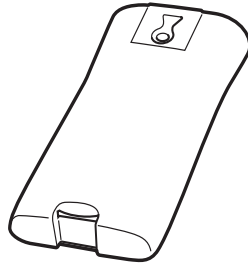

Ni-MH Battery

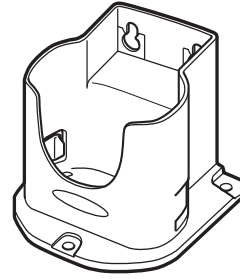

Cradle

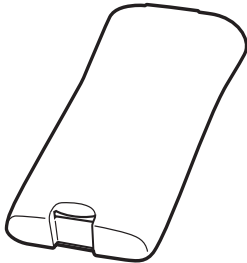

Alkaline Battery Case

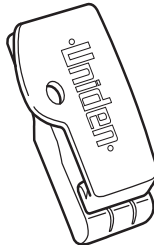

Beltclip



Specifications

General

Freq. Control		PLL
Freq. Tol.	Transmit	1.5 PPM (at 25°C)
	Receive	1.5 PPM (at 25°C)
Oper. Temp.		D15°C to +55°C
Antenna		Flexible Whip
Microphone		Built-in Electret type
Display		Liquid Crystal Display
Speaker		80 Ω, 1 Watt
Power Source		Rechargeable Ni-MH Battery Pack
		7.2V 1350 mAh
Size (without antenna)		5.8 (H) x 2.7 (W) x 1.68 (D) inch
		144 (H) x 67 (W) x 42 (D) mm
Weight (w/battery & antenna)		15.2 oz (430g)

Transmitter

Frequency Range	156~158 MHz
Frequency Stability	±10 PPM
Power Output	1.0 W & 5W
Spurious Emissions	0.03 μW
Current Drain	700mA (1W), 1300mA (5W)

Receiver

Receiver Type	Double Conversion Super Heterodyne Phase Locked Loop system for Local Oscillator
Frequency Range	156~163 MHz
Sensitivity (20 dB SINAD)	-3 dBμV (emf)
Squelch Sensitivity	Tight 1μV
Audio	±6 dB 500 to 2000Hz
Frequency Response	
Adjacent Channel Selectivity	70 dB @ ±25 kHz
Audio Output Power	0.4 W @ 10 % THD
Current Drain	Squelched 40mA
	Max. Audio 160mA

Specifications shown are typical and subject to change without notice.





Troubleshooting

■ Not enough range

Cause: Line of sight blocked

- » Increase antenna height.

■ Will not transmit on 5 watt range but will transmit on the 1 watt range.

Cause: Low voltage

- » Recharge or replace the batteries.

■ Will not transmit while charging.

Cause: Low voltage

- » The radio is not designed to transmit while charging. DC or AC adaptor does not supply enough power for transmitting.

■ Battery will not charge.

Cause: Low voltage

- » Do not to transmit while charging. The adaptor does not supply enough power for transmitting.





Warranty

UNIDEN ATLANTIS 250 MARINE RADIO

One Year Limited Warranty

Important: Evidence of original purchase is required for warranty service.

Warrantor: Uniden Australia Pty Limited A.B.N. 58 001 865 498

Uniden New Zealand Limited

Warranty only available in original country of purchase.

ELEMENT OF WARRANTY:

Uniden warrants to the original retail owner for the duration of this warranty, its Atlantis 250 (herein after referred to as the Product), to be free from defects in materials and craftsmanship with only the limitations or exclusions set out below.

WARRANTY DURATION:

This warranty to the original retail owner only, shall terminate and be of no further effect ONE (1) year after the date of original retail sale. This warranty will be deemed invalid if the Product is;

- (A) Damaged or not maintained as reasonable and necessary,
- (B) Modified, altered or used as part of any conversion kits, subassemblies, or any configurations not sold by Uniden,
- (C) Improperly installed,
- (D) Repaired by someone other than an authorized Uniden Repair Agent for a defect or malfunction covered by this warranty,
- (E) Used in conjunction with any equipment or parts or as part of a system not manufactured by Uniden, or
- (F) Where the Serial Number label of the product has been removed or damaged beyond recognition.

Warranty only valid in the country of original retail/sale.

PARTS COVERED:

This warranty covers for one (1) year, the Product and included accessories.

STATEMENT OF REMEDY:

In the event that the Product does not conform to this warranty at any time while this warranty is in effect, the warrantor at its discretion, will repair the defect or replace the Product and return it to you without charge for parts or service. This warranty does not provide for reimbursement or payment of incidental or consequential damages.

This EXPRESS WARRANTY is in addition to and does not in any way affect your rights under the TRADE PRACTICES ACT 1974 (Cth) (Australia) or the CONSUMER GUARANTEES ACT (New Zealand).

PROCEDURE FOR OBTAINING PERFORMANCE OR WARRANTY:

In the event that the Product does not conform to this warranty, the Product should be shipped or delivered, freight pre-paid, with evidence of original purchase (e.g. a copy of the sales docket), to the warrantor at:

UNIDEN AUSTRALIA PTY LIMITED
 SERVICE DIVISION
 345 Princes Highway, Rockdale NSW 2216
 Fax (02) 9599 3278
www.uniden.com.au

UNIDEN NEW ZEALAND LIMITED
 SERVICE DIVISION
 150 Harris Road, East Tamaki, Auckland
 Fax (09) 274 4253
www.uniden.co.nz





Memo:





Memo:





Uniden®

©2007 Uniden Australia Pty Limited, Uniden New Zealand Limited.
Printed in China.
UTZZ01620ZC(0)

