

# Panasonic®

## Installation Instructions

## 설치 설명서

Model: **CQ-VX220W**



- Please read these instructions carefully before using this product and keep this manual for future reference.
- 본 제품의 바른 사용을 위해, 이 사용설명서를 잘 읽어 주십시오. 잘 보관하시어 필요하실 때마다 읽어주시기 바랍니다.

### Electrical Connections / 전기 접속

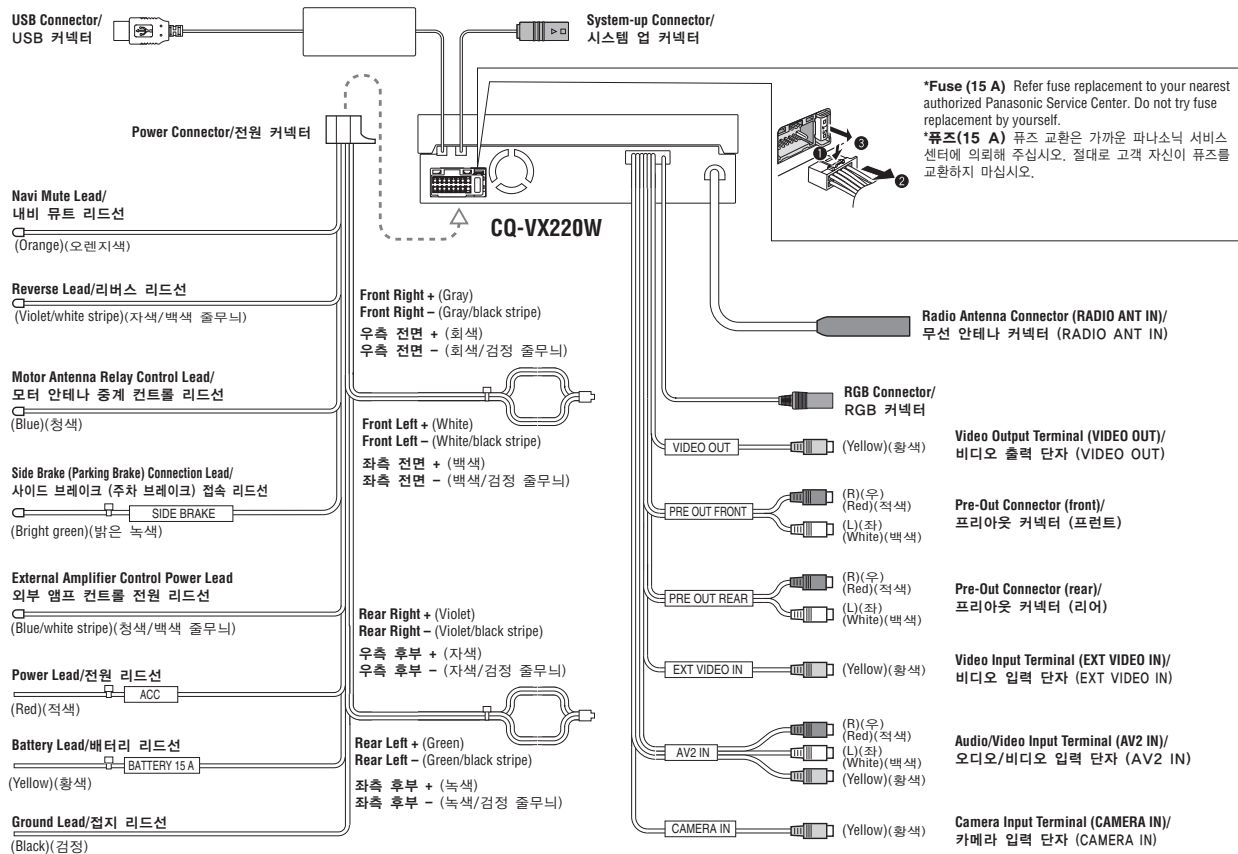

# Safety Information

English

1

## Caution

- PLEASE FOLLOW THE LAWS AND REGULATIONS OF YOUR STATE, PROVINCE OR COUNTRY FOR INSTALLATION OF THE UNIT.
- TO REDUCE THE RISK OF FIRE OR ELECTRIC SHOCK OR PRODUCT DAMAGE, DO NOT EXPOSE THIS APPLIANCE TO RAIN, SPLASHING, DRIPPING OR MOISTURE.

# Upgrade Options

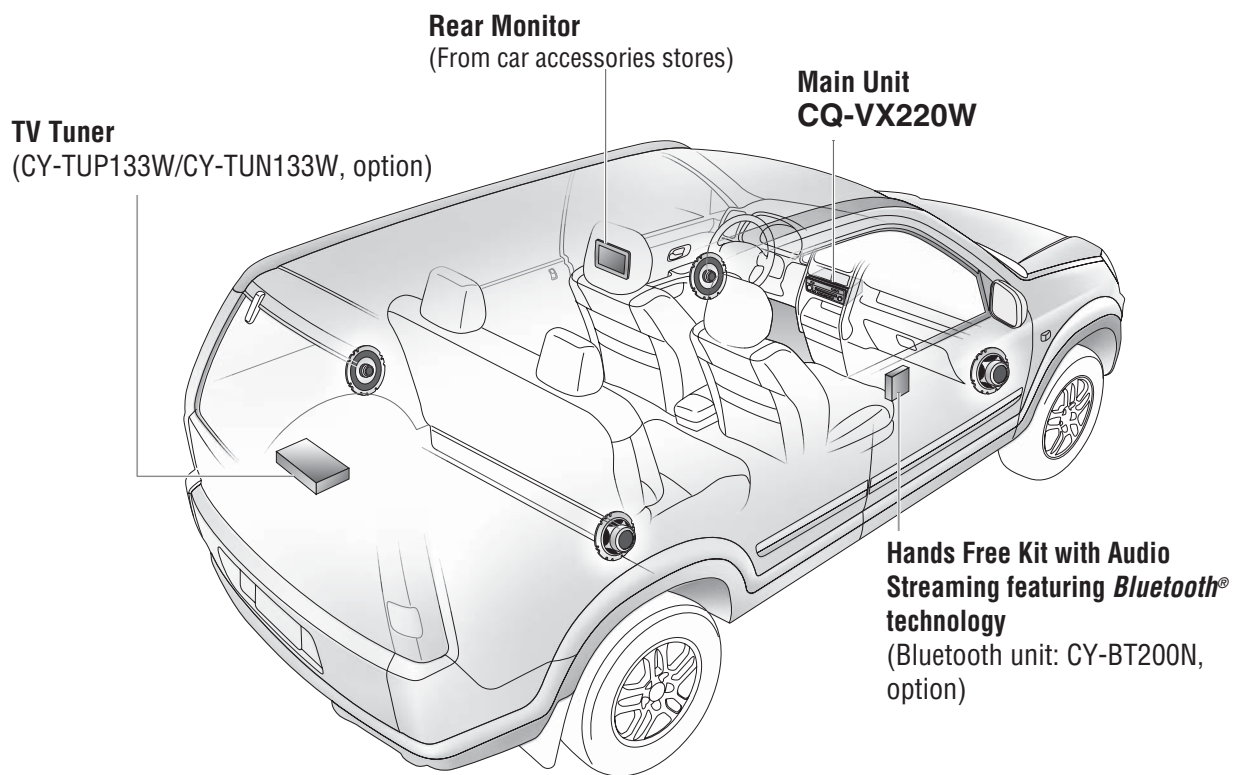

# Contents

Safety Information.....	2
Upgrade Options.....	3
Installation.....	4
Electrical Connections.....	10

# Installation

## Preparation

### ⚠ Caution

- Please follow the laws and regulations of your province or country for installation of the unit.
- When bending the mounting tab of the mounting collar with a screwdriver, be careful not to injure your hands and fingers.
- We strongly recommend you to wear gloves for installation work to protect yourself from injuries.

- Before installation, check the radio operation with antenna and speakers.
- Disconnect the cable from the negative (-) battery terminal (see caution below).
- The unit should be installed in a horizontal position with the front end up at a convenient angle, but not more than 30°.

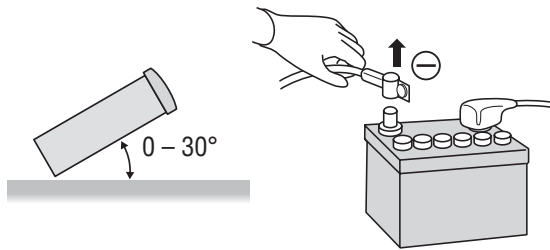

### ⚠ Caution

- Do not disconnect the battery terminals of a car with trip or navigational computer since all user settings stored in memory will be lost. Instead take extra care with installing the unit to prevent shorts.

## Dashboard Installation

### Installation Opening

The unit can be installed in any dashboard having an opening as shown below. The dashboard should be 4.5 mm – 6 mm thick in order to be able to support the unit.

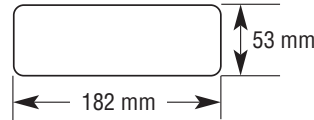









### Installation Precautions

**This product should be installed by a professional installer, if possible.**



In case of difficulty, please consult your nearest authorized Panasonic Service Center.

1. This system is to be used only in a 12 V DC battery system (car) with negative ground.
2. Follow the electrical connections carefully (⇒ page 10-17). Failure to do so may result in damage to the unit.
3. Connect the power lead after all other connections are made.
4. Be sure to connect the battery lead (yellow) to the positive terminal (+) of the battery or fuse block (BAT) terminal.
5. Insulate all exposed wires to prevent short circuiting.
6. Secure all loose wires after installing the unit.
7. Please carefully read the operating and installation instructions of the respective equipment before connecting it to this unit.

## ❑ Installation Hardware (For Installation)

No.	Item	Diagram	Qty.
①	Trim Plate		1
		<YFC054C087CA>	
②	Mounting Collar		1
		<YFX214C433CA>	
③	Mounting Spring		2
		<YFX054C077CA>	
④	Mounting Bolt (5 mmø)		1
		<YEJV014C002N>	
⑤	Round Head Screw (5 mmø x 6 mm)		2
⑥	Flat-Head Screw (5 mmø x 6 mm)		4
⑦	Round Head Screw (4 mmø x 3 mm)		4
		<ZZBISVD7005B>	
⑧	Spacer		2
⑨	Double-Faced Adhesive Tape		1 set
		<ZZBISVD7005E>	

## ❑ Installation Hardware (For Wiring)

No.	Item	Diagram	Qty.
⑩	Power Connector		1
		<YAJ024C125CA>	
⑪	Conversion Cable for AV1 IN		1
		<YEAERA33000K>	

### Note:

- The number in parenthesis underneath each accessory part name is the part number for maintenance and service.
- Accessories and their parts numbers are subject to modification without prior notice due to improvements.
- Use the supplied screws for installation exclusively. In case of losing any of them, please order the specific screw.

## ❑ Transportation Bracket Removal

Be sure to remove the transportation brackets before use (installation).

**Use round head screws (5 mmø x 6 mm) for installation.** (→ page 8)

Be careful not to lose these screws.

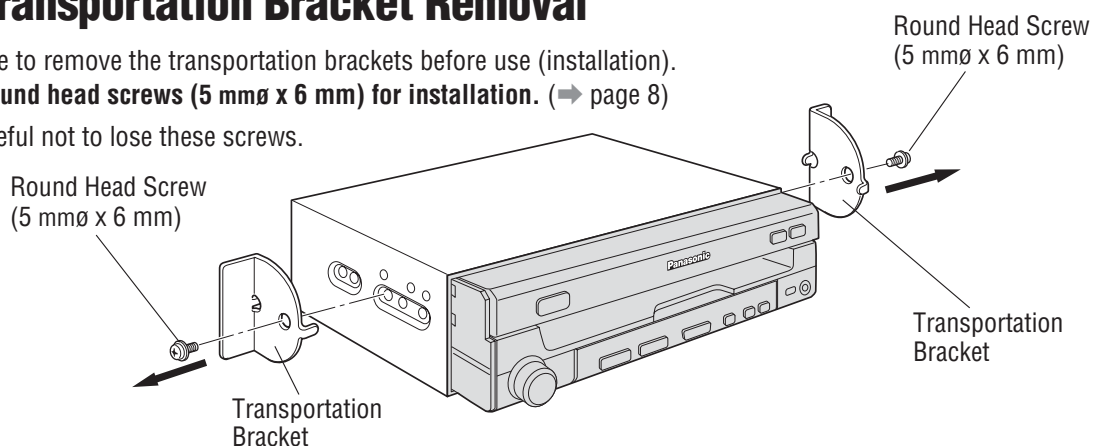

# Installation (continued)

## Mounting the Main Unit

### Installation Procedures (When using Mounting Collar ②)

5

**Note:**

- The car model, installation conditions and combination of the units used may impose some restrictions on opening and closing the monitor as well as on the angle and position to which the monitor can be adjusted.

**IMPORTANT**

When this unit is installed in dashboard, ensure that there is sufficient air flow around the unit to prevent damage from overheating. Do not block any ventilation holes on the unit.

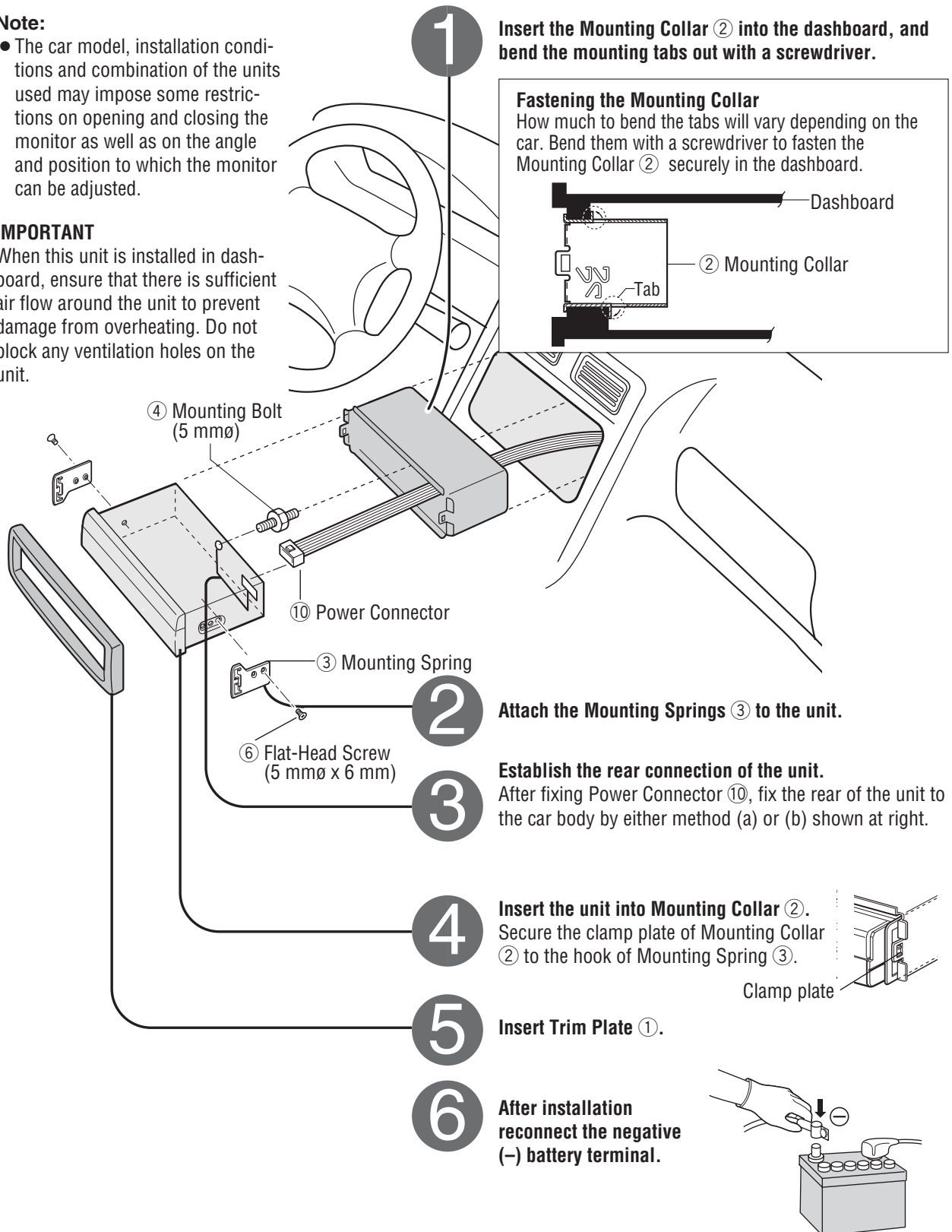

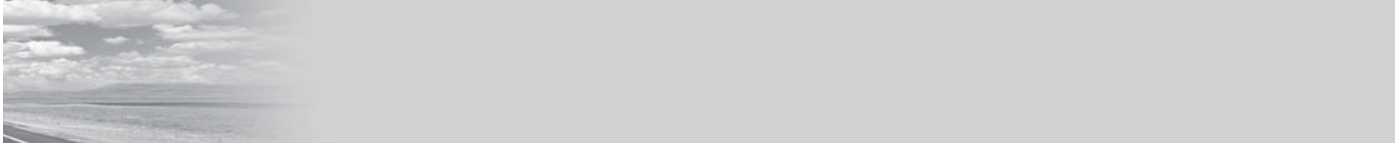

## Method for Fixing the Mounting Spring

Two holes of the mounting spring allow you to select between two mounting types as shown below.

### (A) Regular installation method

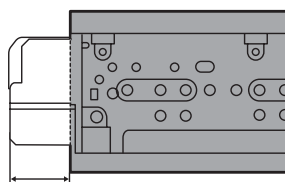

A few millimeters of console projecting

⑥ Flat-Head Screw

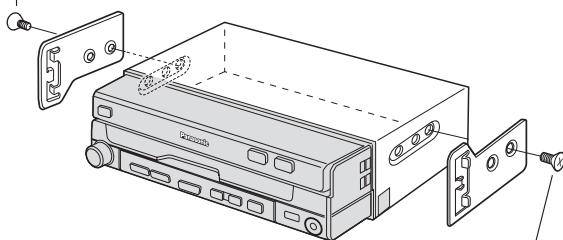

⑥ Flat-Head Screw

### (B) Deeper installation method

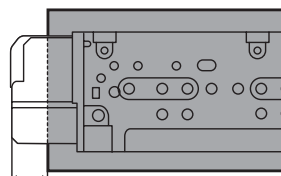

Less projecting

⑥ Flat-Head Screw

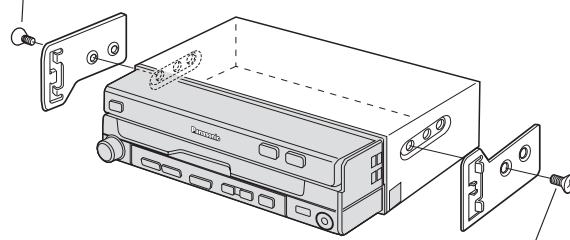

⑥ Flat-Head Screw

### ⚠ Caution

- Method (B) is not available in some types of cars.

## Method for Fixing the Rear of the Unit

### (a) Using the Rear Support Strap (option)

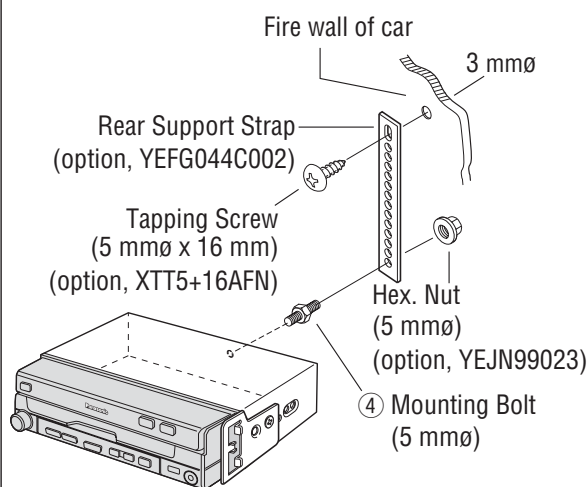

### (b) Using the Rubber Cushion (option)

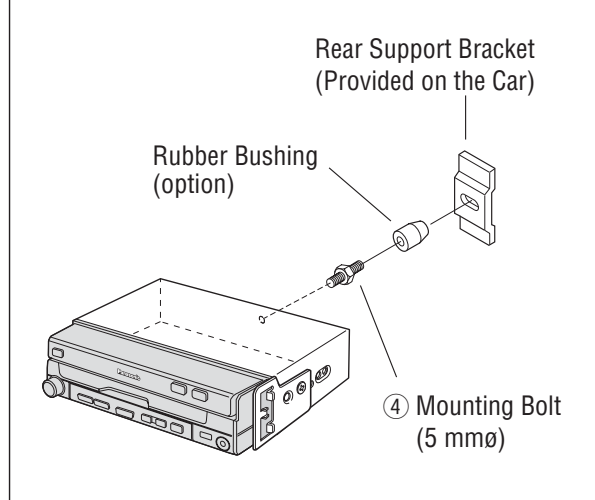



# Installation (continued)





## Installation Procedures (When not using Mounting Collar ②)

7

Use the brackets supplied with your car when mounting this unit. The bracket shape and mounting method vary with car manufacturers, car types and manufacturing year. Please consult your nearest dealer or installer.

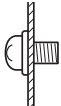
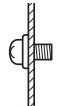
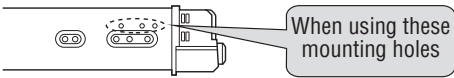
Select mounting screws according to the hole positions and hole shape of the bracket.

	⑤ Round Head Screw (5 mm $\phi$ x 6 mm)      2 pieces Reuse the two round head screws removed from the transportation brackets.	
	⑦ Round Head Screw (4 mm $\phi$ x 3 mm) 4 pieces	
	⑥ Flat-Head Screw (5 mm $\phi$ x 6 mm)      4 pieces	

Use the supplied Spacer ⑧ if mounting hole of your car is shaped like below.

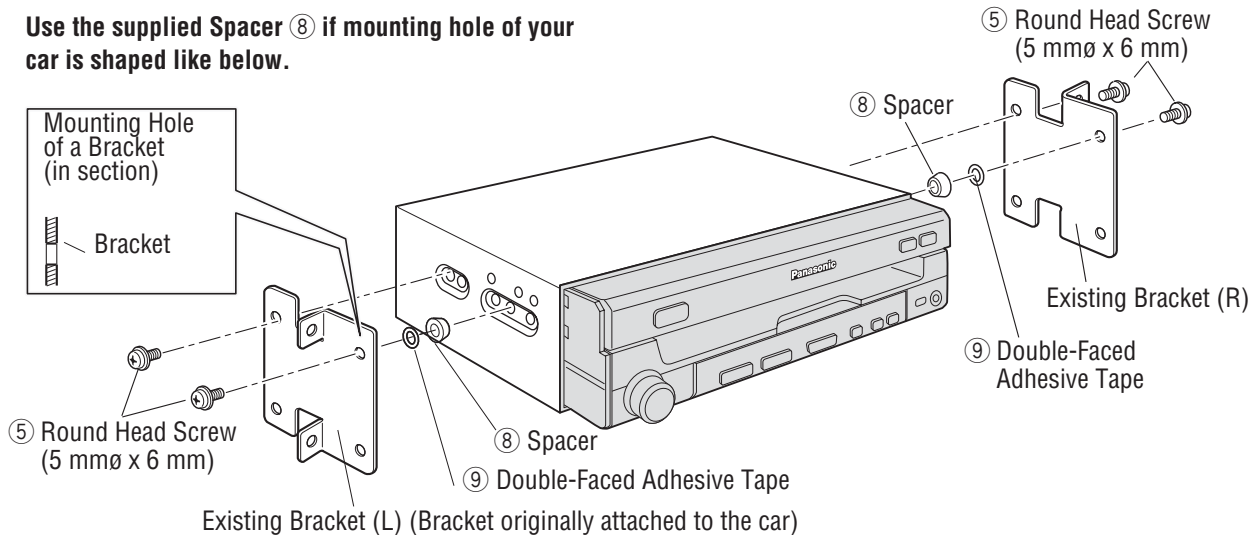

### To Remove the Unit

- ① Push the right and left clamp plates outward, one at a time, and pull the unit toward yourself.
- ② After removing the right and left clamp plates, pull the unit with both hands till it comes out.

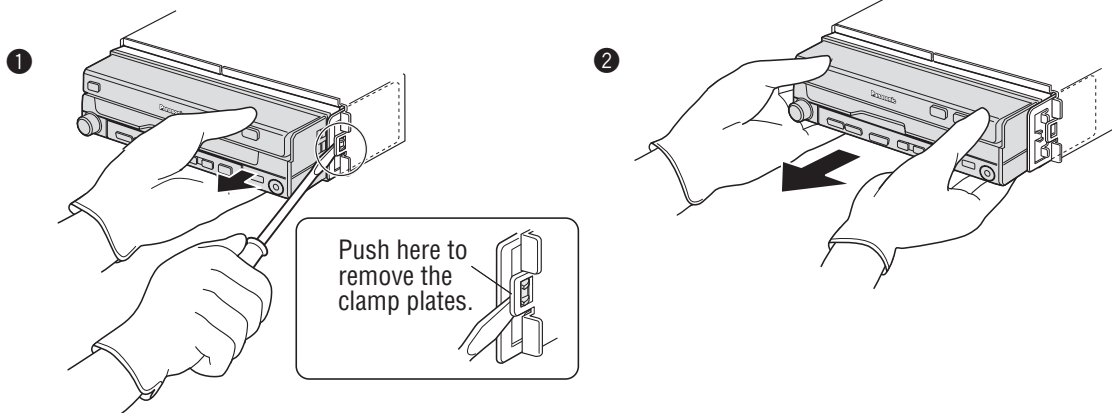



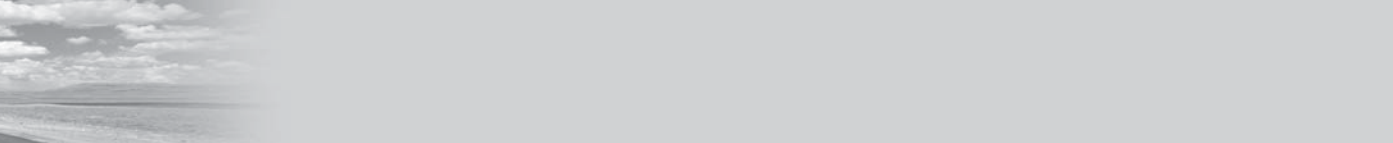

# Connecting the Side Brake (Parking Brake) Connection Lead

## ⚠ Caution

- For safety, be sure to ask your nearest professional installer to do this connection.

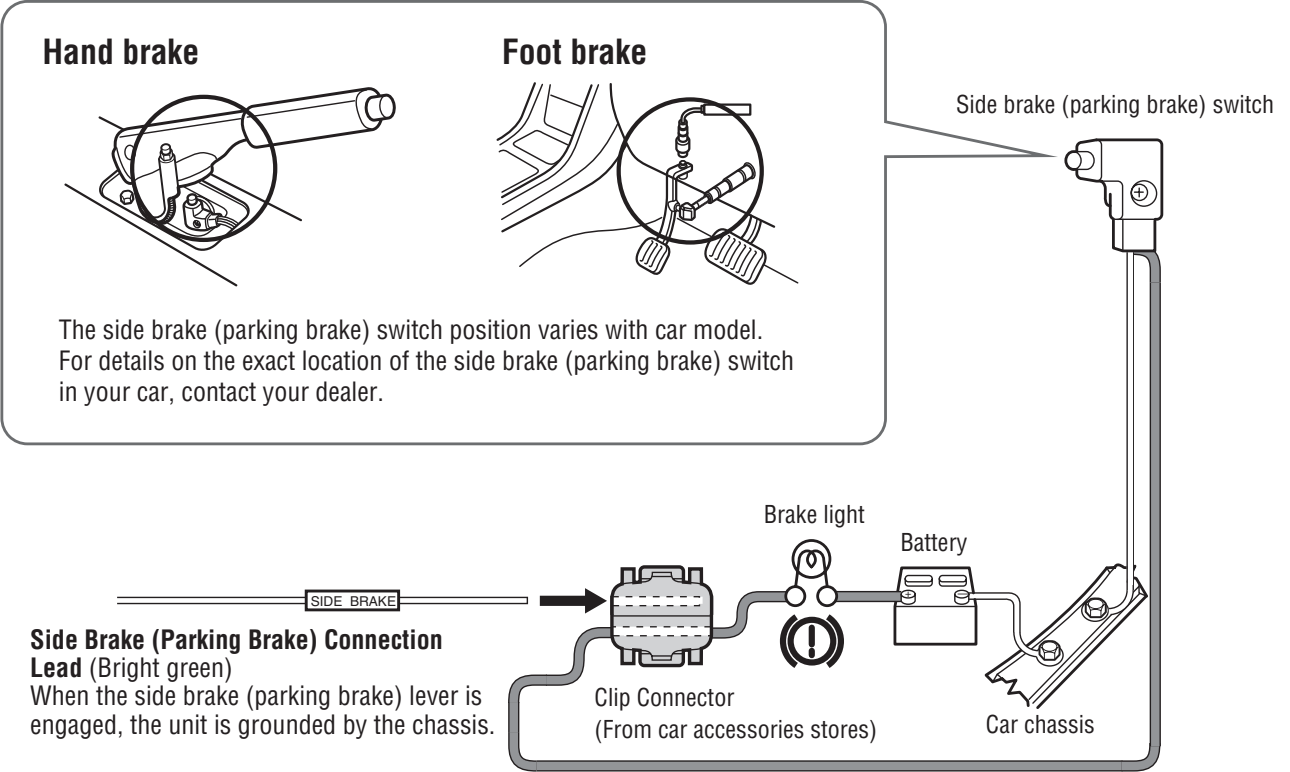

- 1 Attach a Clip Connector to the end of the side brake (parking brake) connection lead.

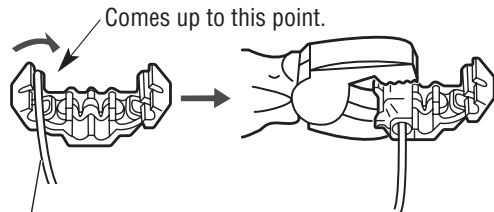

**Side Brake (Parking Brake) Connection Lead (Bright green)**

- 2 The Clip Connector is connected to the power source side lead of the side brake (parking brake) lever.

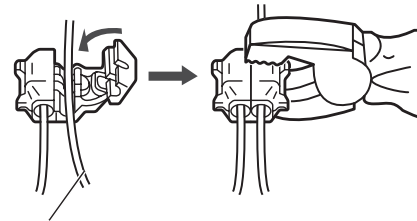

**Power source side lead**

# Electrical Connections

## ⚠ Caution

- This unit is designed for use in a car having a 12 V negative ground battery system.
- Be sure to insulate any exposed wires from the car chassis. Bundle all cables and keep cable terminals free from any metal parts.
- Note that if your car has a driving computer or a navigation computer, disconnecting the cable from the battery may clear the memory.
- Run the cords avoiding the spots where the temperature can be extremely high.

### Navi Mute Lead (Orange)

Connect to the Navi Mute Lead of the Panasonic car navigation system. (available in future)

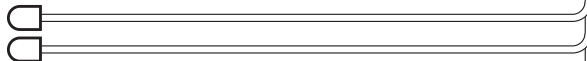

### Motor Antenna Relay Control Lead (Blue)

(To motor antenna) (Max. 100 mA)  
This lead is not intended for use with a switch actuated power antenna.



### Side Brake (Parking Brake) Connection Lead (Bright green)

Be sure to wire the side brake (parking brake) for safety and preventing accidents. (⇒ page 9)



### External Amplifier Control Power Lead (Blue/white stripe)

To an external amplifier.

#### Note:

- Use the power control lead of the TV tuner for TV tuner connection.
- Connect both the power control lead of the TV tuner and the amplifier control connector of the external amplifier when the TV tuner and external amplifier are connected at the same time.

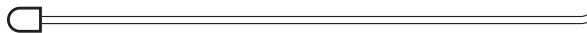

### Reverse Lead (Violet/white stripe)

When connecting the rear view camera, use the reverse lead. (⇒ page 12)



### Power Lead (Red)

To ACC power, +12 V DC.

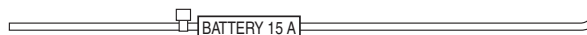

### Battery Lead (Yellow)

To the car battery, continuous +12 V DC.

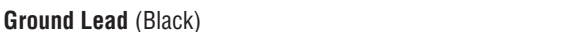

### Ground Lead (Black)

To a clean, bare metallic part of the car chassis

## ⑩ Power Connector

Front Right + (Gray)  
Front Right - (Gray/black stripe)

Front Left + (White)  
Front Left - (White/black stripe)

Rear Right + (Violet)  
Rear Right - (Violet/black stripe)

Rear Left + (Green)  
Rear Left - (Green/black stripe)

### Speaker connections

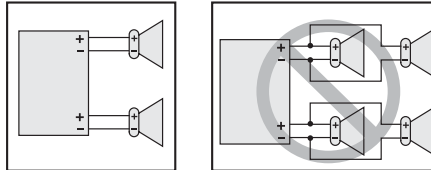

- Do not connect more than one speaker to one set of speaker leads (except for connecting to a tweeter). **Use of speakers which do not match the specifications can cause burning, smoking or damage of the speakers.**
- Do not use a 3-wire type speaker system having a common earth lead.

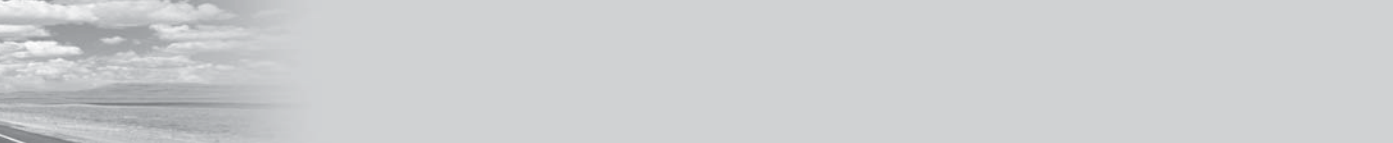

**Note:**

- To prevent from damage to the unit, be sure to follow the wiring diagrams below.
- Be sure to fully plug in the connectors. Secure them with clamps and tapes.
- All other installation methods require the use of dedicated metal fittings. Consult with a qualified servicing engineer or your dealer if other methods are required.
- Installation of this product may interfere with the grounding properly. In such a case, connect the ground lead of the external equipment to be connected to the mounting bolt ④ that secures this product.
- The pre-out connector is used exclusively with an external amplifier. Accordingly, do not connect the audio input terminal or any other external devices to this connector.

    : This book refers to connections to the Panasonic car navigation system that will come onto the market in the future. Descriptions regarding the car navigation system are boxed with a dotted line.

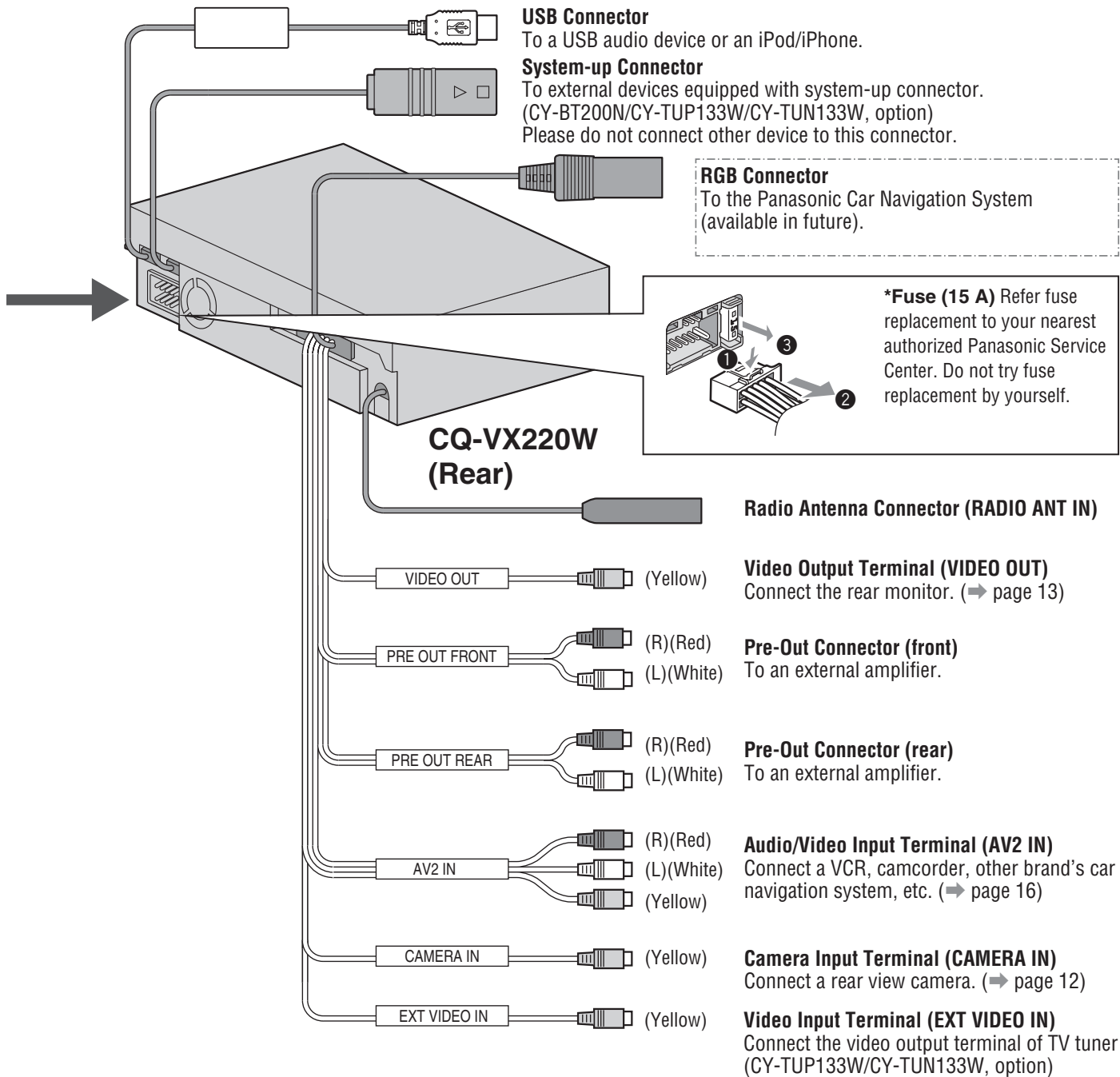

# Electrical Connections (continued)

## Connection with Rear View Camera

**Note:**

- Refer to the operating instructions for the connected devices, in addition.

11

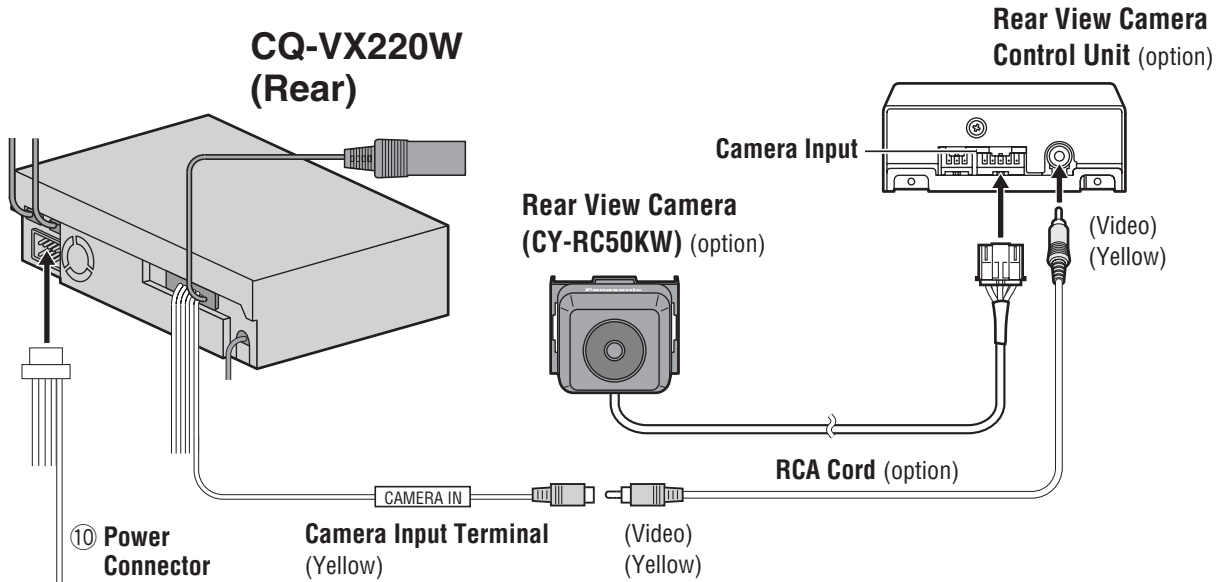

### Connecting the Reverse Lead

If using an optional rear view camera, the reverse lead must be connected.

Connect the reverse lead (violet/white stripe) to the positive (+) lead of the reverse lamp (the lamp with a clear lens that lights when the transmission gear is shifted into the reverse position).

**Note:**

- Connect the reverse lead after cutting the terminal at the end.
- Use a Reverse Extension Cord (option) if needed.

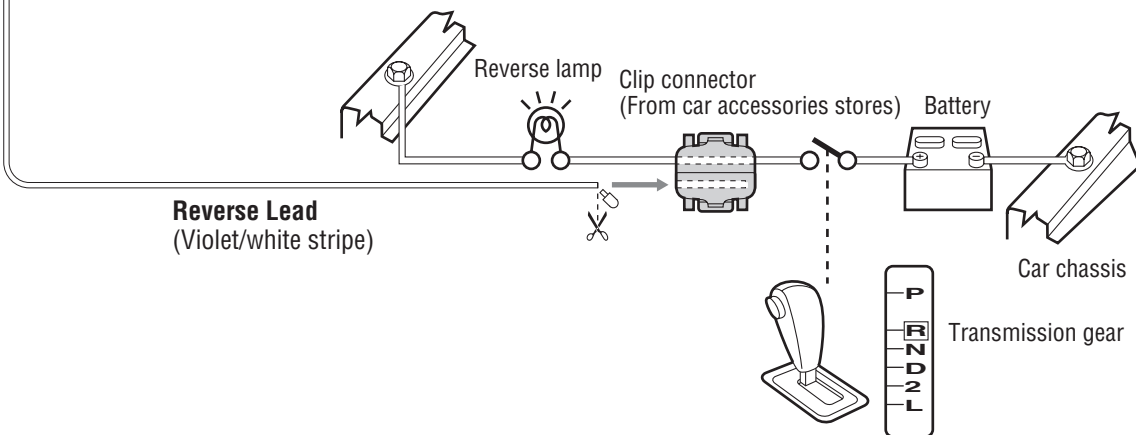
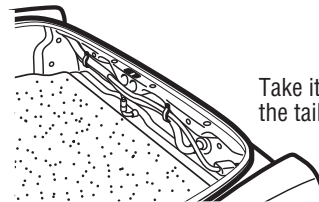
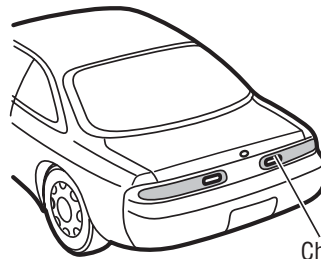

# Connection with Rear Monitor

**Note:**

- Refer to the operating instructions for the connected devices, in addition.
- Please observe what shapes the connectors of the connecting devices are and where each of them is connected to in order to establish a proper connection.

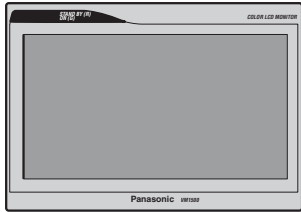

Rear Monitor

**Caution**

- For people sitting in the front seats, please enjoy only audio during driving.

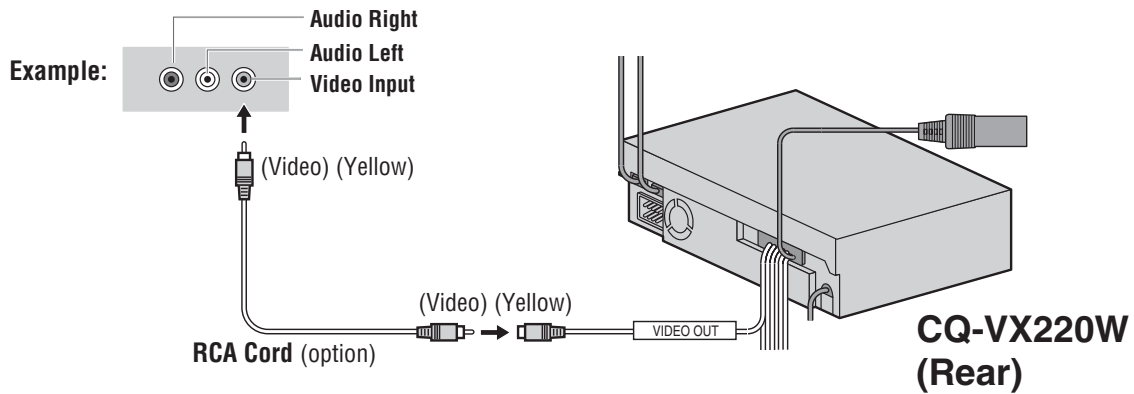

# Electrical Connections (continued)

## Connection with TV Tuner

**Note:**

- Refer to the operating instructions for the connected devices, in addition.

13

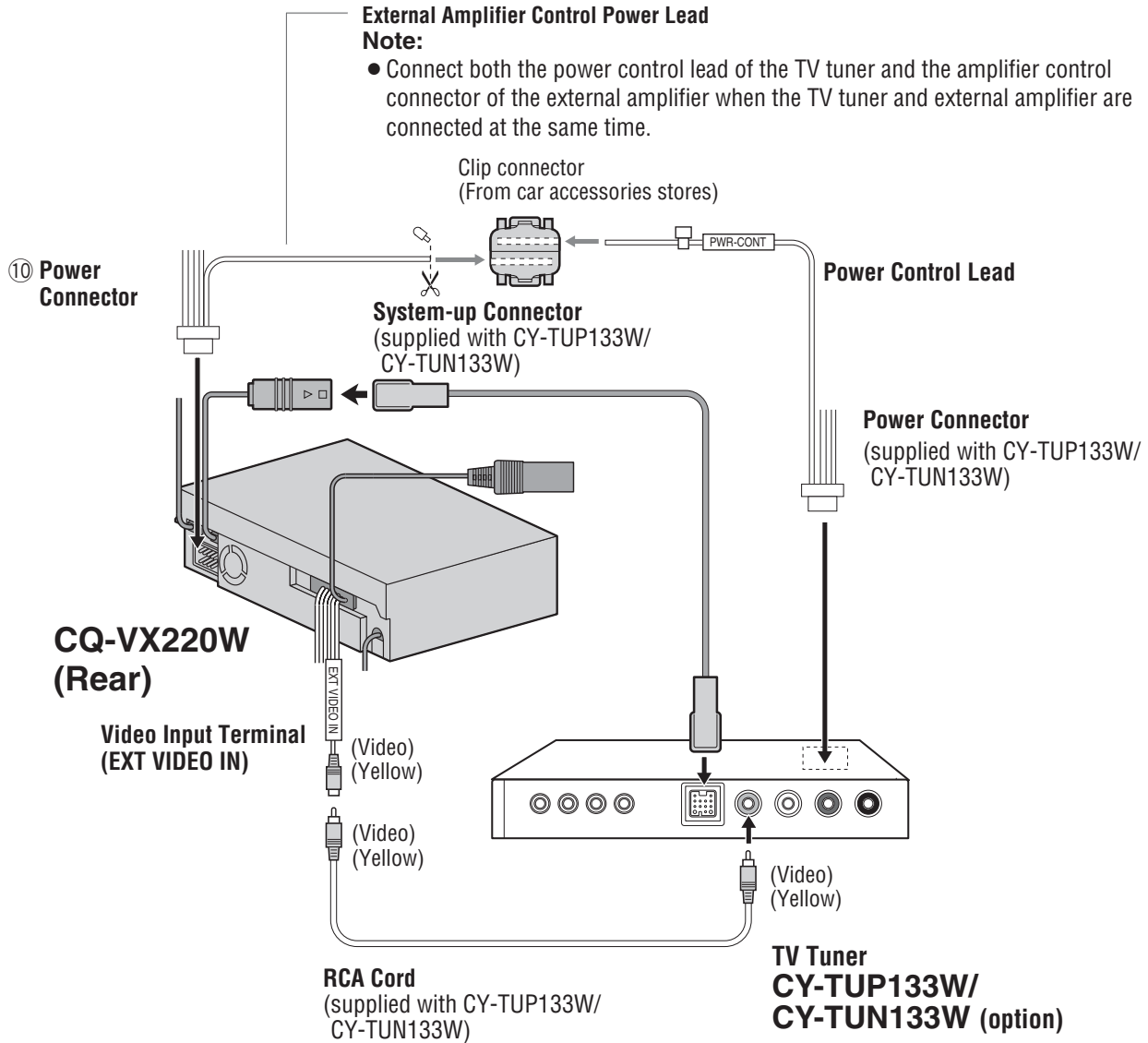

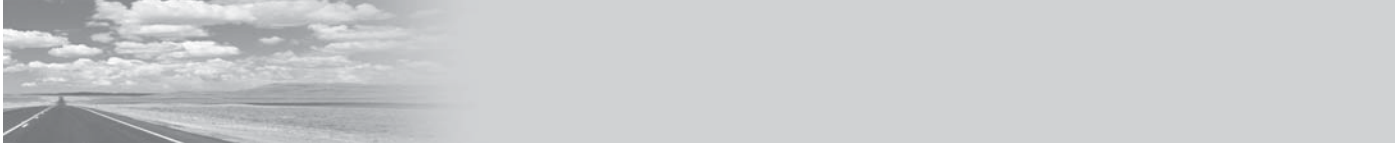

## Connection with VCR or Camcorder (AV1 IN)

**Note:**

- Refer to the operating instructions for the connected devices, in addition.
- Please observe what shapes the connectors of the connecting devices are and where each of them is connected to in order to establish a proper connection.

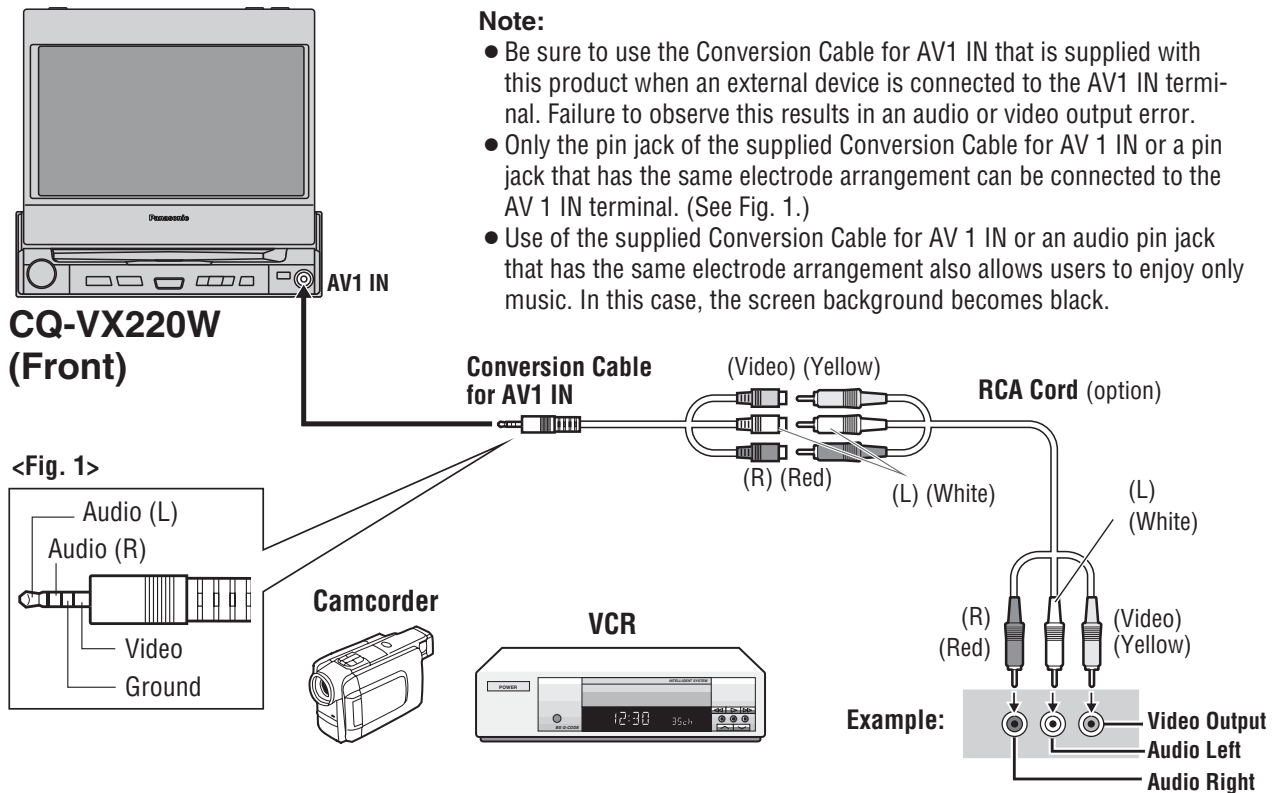

## Connection with USB Device or iPod/iPhone

**Note:**

- Refer to the operating instructions for the connected devices, in addition.
- Please observe what shapes the connectors of the connecting devices are and where each of them is connected to in order to establish a proper connection.
- For video browsing of the iPod/iPhone, please use the optional Direct Cable for iPod with Video (CA-LDC100X) for connection with AV1 IN connector of this unit. (Do not connect with AV2 IN connector)

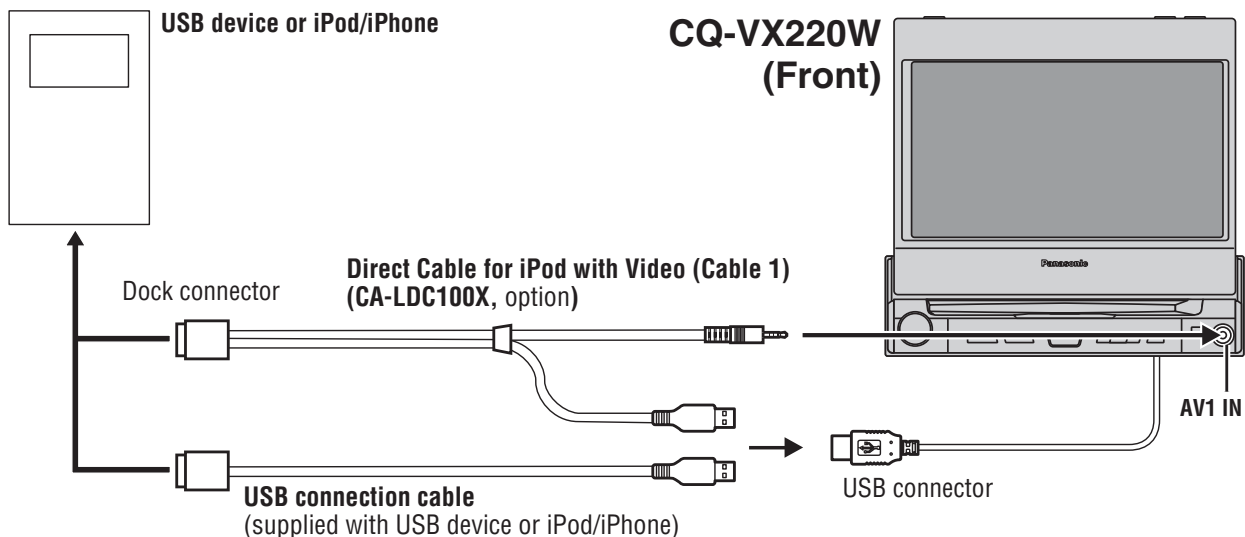



# Electrical Connections (continued)

## Connection with VCR or Camcorder (AV2 IN)

**Note:**

- Refer to the operating instructions for the connected devices, in addition.
- Please observe what shapes the connectors of the connecting devices are and where each of them is connected to in order to establish a proper connection.

15

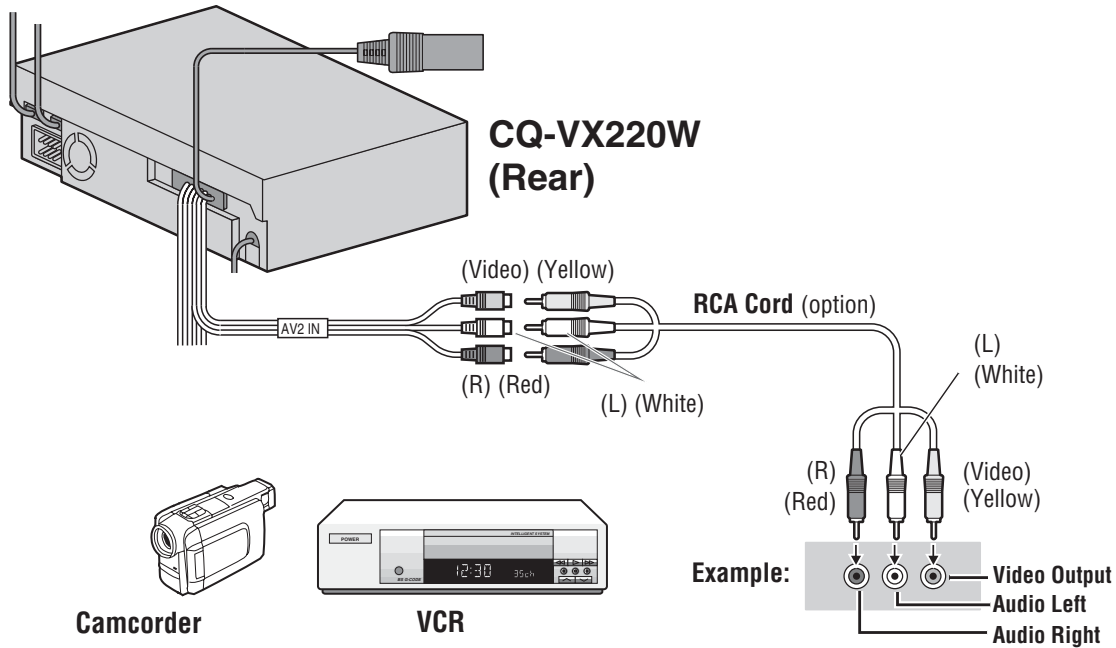

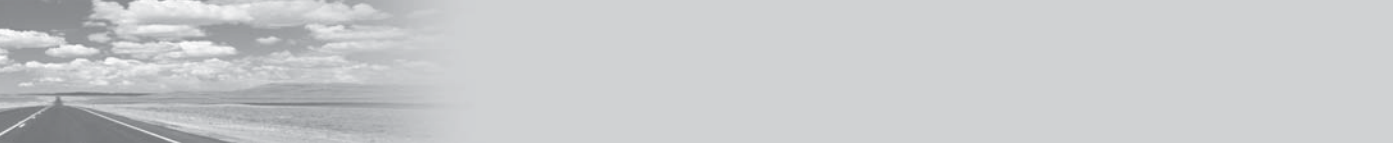

# Connection with CY-BT200N (Bluetooth Unit)

**Note:**

- Refer to the operating instructions for the connected devices, in addition.
- Please observe what shapes the connectors of the connecting devices are and where each of them is connected to in order to establish a proper connection.

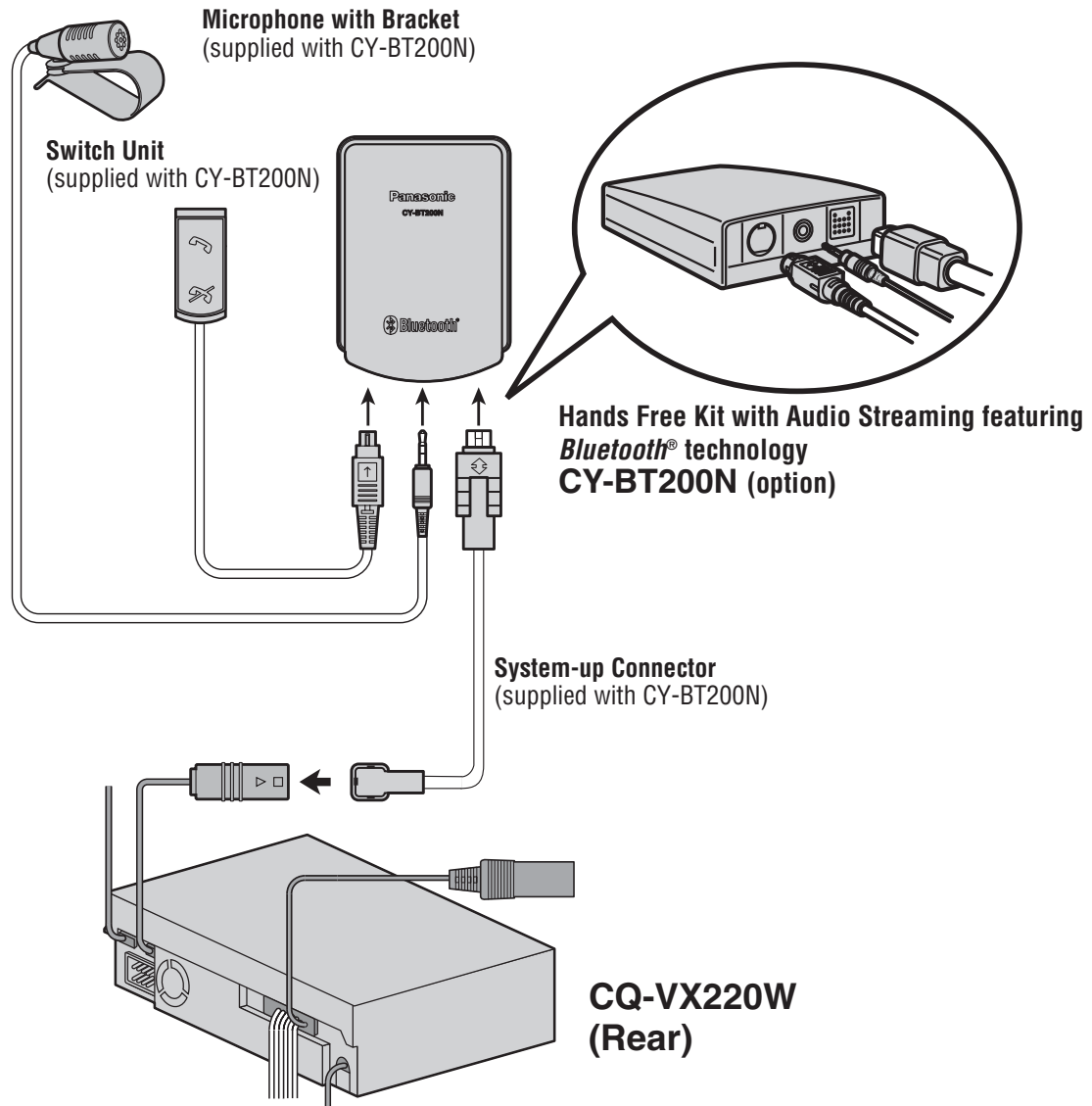

# Memorandum



A series of horizontal dotted lines for writing, spanning the width of the page.

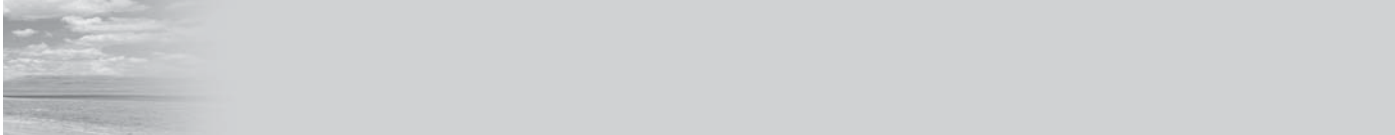

A series of horizontal dotted lines spanning the width of the page, providing a guide for writing.

**Panasonic**<sup>®</sup>

**Installation Instructions**

**Panasonic Corporation**

Web Site : <http://panasonic.net>

YFM294C151CA PTW1208-1029

Printed in China