

**Uniden<sup>®</sup>**

**TRAX5000**  
**In-Car Navigation**

**OWNER'S MANUAL**

Thank you for purchasing this Uniden product. Read the Quick Start Guide first and start using your device right away. This document is the detailed description of the navigation software. You can easily discover your device while you are using it; however, we still recommend that you read this manual to fully understand the screens and the features of your software.

# Table of Contents

---

<b>What Do I Do First?</b>	<b>6</b>
Make Sure These Items Arrived in the Box	6
Plug it in	7
<b>Hardware Keys</b>	<b>8</b>
<b>How Do I Put It in My Car?</b>	<b>9</b>
Safety considerations	9
Attaching the windshield mount	10
Adjusting the windshield mount	11
Mounting on the windshield	11
<b>1 Warnings and Safety information</b>	<b>12</b>
<b>2 Getting started</b>	<b>13</b>
2.1 Startup screen: the Navigation menu	16
2.2 Hardware buttons	17
2.3 Buttons and other controls on the screen	17
2.3.1 Using keyboards	19
2.3.2 Beyond single screen tap	20
2.4 Map screen	21
2.4.1 Navigating on the map	21
2.4.2 Position markers	24
2.4.2.1 Vehimarker and Lock-on-Road	24
2.4.2.2 Selected location (Cursor) in Find on Map	25
2.4.3 Objects on the map	25
2.4.3.1 Streets and roads	25
2.4.3.2 Turn Preview and next street	25
2.4.3.3 Lane information and Signposts	27
2.4.3.4 3D object types	27
2.4.3.5 Elements of the active route	28
2.4.4 Manipulating the map	29

2.4.5 Quick menu.....	31
2.4.6 Checking the details of the current position (Where Am I?).....	33
<b>3 Navigating.....</b>	<b>35</b>
3.1 Selecting the destination of a route.....	35
3.1.1 Entering an address or part of an address.....	35
3.1.1.1 Entering an address.....	36
3.1.1.2 Entering the midpoint of a street as the destination.....	39
3.1.1.3 Selecting an intersection as the destination.....	42
3.1.1.4 Selecting a city/town centre as the destination.....	45
3.1.1.5 Entering an address with a postal code.....	48
3.1.1.6 Tips on entering addresses quickly.....	51
3.1.2 Selecting the destination from the Places of Interest.....	52
3.1.2.1 Selecting the destination from the Places of Interest with Quick search.....	52
3.1.2.2 Selecting the destination from other Places of Interest by name.....	55
3.1.2.3 Selecting the destination from other Places of Interest by category.....	58
3.1.2.4 Selecting nearby assistance from 'Where Am I?'.....	62
3.1.3 Selecting a map location as the destination.....	65
3.1.4 Selecting the destination from your Favourites.....	66
3.1.5 Selecting the most likely destination (Smart History).....	67
3.1.6 Selecting the destination from the History.....	68
3.2 Viewing the entire route on the map.....	69
3.3 Checking the route parameters.....	70
3.4 Modifying the route.....	71
3.4.1 Replacing the destination of the route.....	71
3.4.2 Setting a new starting position for the route.....	72
3.4.3 Pausing the active route.....	73
3.4.4 Deleting the active route.....	74
3.4.5 Changing the route planning method.....	74
3.4.6 Checking the route alternatives.....	76
3.4.7 Changing the vehicle used in route planning.....	77

3.4.8 Changing the road types used in route planning.....	79
3.5 Adding the destination of the route to Favourites.....	80
3.6 Watching the simulation of the route.....	82
<b>4 Reference Guide.....</b>	<b>84</b>
4.1 Concepts.....	84
4.1.1 Smart Zoom.....	84
4.1.2 Daytime and night colour themes.....	84
4.1.3 Colour theme in tunnels.....	84
4.1.4 Route calculation and recalculation.....	85
4.1.5 Road Safety Cameras.....	86
4.1.5.1 Camera types.....	86
4.1.5.2 Camera directions.....	88
4.1.6 Speed limit warning.....	88
4.1.7 Battery and GPS position quality indicators.....	88
4.2 'More' menu.....	89
4.3 Settings menu.....	91
4.3.1 Route settings.....	92
4.3.2 Sound settings.....	94
4.3.3 3D vehicle gallery.....	95
4.3.4 Colour themes.....	96
4.3.5 Set starting position.....	97
4.3.6 Regional settings.....	97
4.3.7 Content.....	98
<b>5 Glossary.....</b>	<b>100</b>
<b>6 End User Licence Agreement.....</b>	<b>103</b>
<b>7 Limited One Year Warranty.....</b>	<b>109</b>

# What Do I Do First?

---

## Make Sure These Items Arrived in the Box

If anything listed here is missing or damaged, contact your place of purchase immediately.

▶ **TRAX5000 GPS navigation device**

Press the suspend  button at the TOP of the device to turn the navigation on or off.



Part 1



Part 2

▶ **Windshield Mount (2 part)**

▶ **Owners Manual**

▶ **Quick Start Guide sheet**





▶ **DC (car) adapter**



▶ **USB cable**

## Plug it in

- ▶ Connect the power adapter to the power connector on the lower right side of the device.
- ▶ Plug the other end into your car's cigarette lighter (or any standard 12VDC - 24VDC outlet).
- ▶ Only use the power adapter that came with your device. Any other adapter might damage the device.
- ▶ Press and hold the power  button at the top of the device to turn it on/off.
- ▶ Whenever it senses power coming in, the device charges the battery. You can put the device into or out of sleep mode anytime you want: just push and hold the power  button.



# Hardware Keys

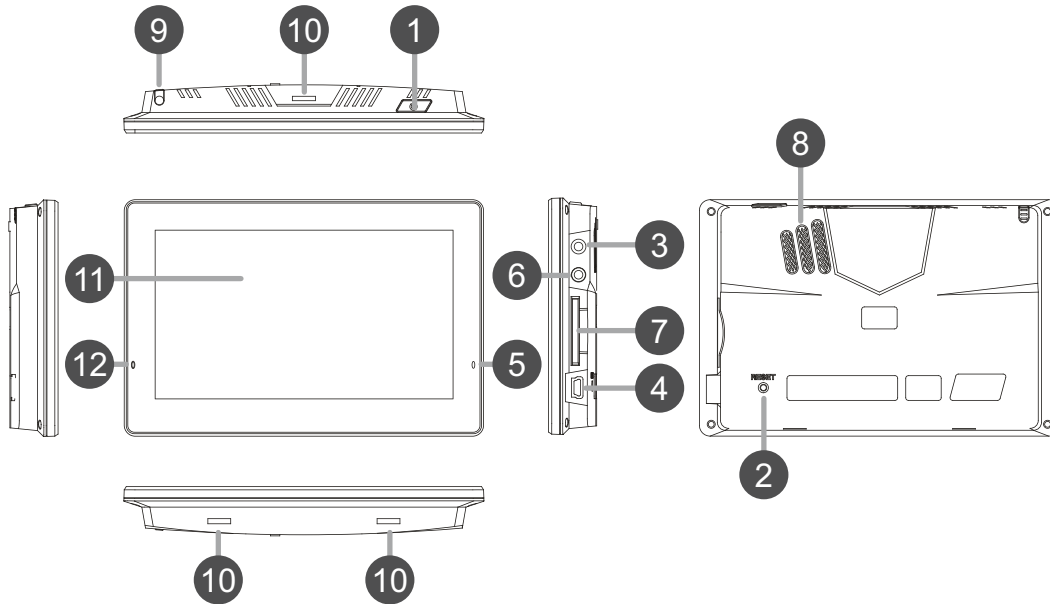

Ref	Component	Description
①	Power Key	Power on/off/sleep
②	Reset	If the device fails to operate properly, try resetting the device. Press the reset button by using the ball point pen or a similar tool.
③	N/A	N/A
④	Mini USB Port	Charge the GPS device by connecting AC adaptor or car charger.
⑤	Power Indicator	The light is red during charging, it will turn green when the battery is fully charged
⑥	Earphone Jack	Earphone Jack
⑦	SD card slot	SD card slot
⑧	Speaker	Speaker
⑨	Touch-pen	Touch-pen
⑩	Bracket Block Slot	Bracket Block Slot
⑪	Display Screen	Display Screen
⑫	N/A	N/A



# How Do I Put It in My Car?

---

## Safety Considerations

- ▶ Don't install any device where it will block your view (including your mirrors!) while you're driving.
- ▶ **Keep your attention on the road!** Don't try to operate or focus on any device while you're driving. If you have to concentrate on a device, pull off the road for a few minutes.
- ▶ It's a good idea to take valuable items with you when you leave your car—that includes GPS devices. If you can't take the device with you, lock it in the glove compartment or hide it somewhere. And don't forget to take down the windshield mount: you don't want to remind any potential thieves that you might have some valuable mobile electronics in the car.

---

*Don't leave the device in direct sunlight for a long period of time or where the temperature could go above 60° C (140° F).*

---

## Attaching the windshield mount

Assemble the Windshield mount.

- 1) Loosen the locking collar on part 2.
- 2) Push the ball joint of Part 1 through the locking collar into part 2.



- ▶ Insert the bracket hook into the notches at the bottom of the device.



- ▶ Rotate the bracket up so the head fits into the gap.

## Adjusting the Windshield Mount

- ▶ Turn the windshield mount arm to a suitable angle for mounting.



## Mounting on the Windshield

---

*Make sure the device does not block your view of the road or your mirrors.*

---

Once you decide where you want the device, hold the suction cup in that position, then adjust the mount so you have the best view of the device.

- 1) Press the suction cup flat against the windshield.
- 2) Push the suction lock up (clockwise) until it snaps into place.
- 3) Adjust the unit & bracket to a final position. Tighten the locking collar to secure.
- 4) Gently pull on the mount to make sure it is secure.

If you have trouble getting the suction cup to stick:

- ▶ Clean the spot with an ammonia-free cleanser.
- ▶ Dry the spot completely (use a lint-free cloth, if possible).
- ▶ Make sure the spot is smooth and flat (suction cups won't stick well on a curved or textured surface).

## Removing the windshield mount

---

*When you release the suction latch, make sure you're holding or somehow supporting the device.*

---

Lift the suction latch and use the plastic pull tab to pull the suction cup off of the glass.

---

# 1 Warnings and Safety information

---

This software is a navigation system that helps you find your way to your destination with the built-in GPS receiver. The software does not transmit your GPS position; others cannot track you.

It is important that you look at the display only when it is safe to do so. If you are the driver of the vehicle, we recommend that you operate your software before you start your journey. Plan the route before your departure and stop if you need to change the route.

You must obey the traffic signs and follow the road geometry. If you deviate from the recommended route, your software changes the instructions accordingly.

Never place your device where it obstructs the driver's view, where it is in the deployment zone of an airbag or where it might cause injuries in an accident.

For more information, consult the End User Licence Agreement (page 103).

## 2 Getting started

---

The software is optimised for in-car or pedestrian use. There is no need to use a stylus. You can use it easily by tapping the screen buttons and the map with your fingertips.

When using the navigation software for the first time, an initial setup process starts automatically. Do as follows:

1. Select the written language of the application interface. Later you can change it in Regional settings (page 97).



2. Read and accept the End User Licence Agreement.

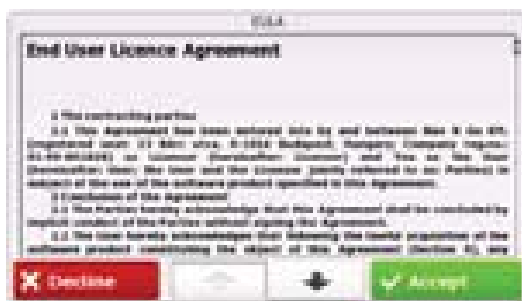

3. The Configuration wizard starts in the selected language. Tap  to continue.
4. Select the language and speaker used for voice guidance messages. Later you can change it in Regional settings (page 97).

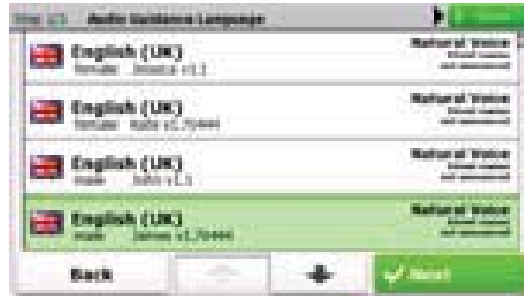



5. If needed, modify the time format, time zone and unit settings. Later you can change them in Regional settings (page 97).



6. If needed, modify the default route planning options. Later you can change them in Route settings (page 92).



7. The initial setup is now complete. Tap  to proceed. The Configuration wizard can be restarted later from the Settings menu (page 91).
8. You are offered to watch the Tutorial that leads you through the basic steps of navigation, or to run Demo route simulations. To start using the software right away, you can tap  to skip the tutorial as you can run it later from the 'More' menu (page 89).

After the initial setup, the Navigation menu appears and you can start using the software. This is the screen you see every time navigation starts.

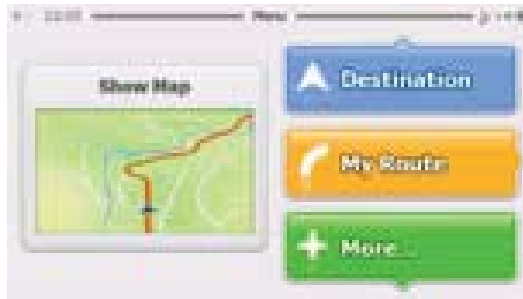

The typical way of using the software is to select a destination, and start navigating. You can select your destination in the following ways:



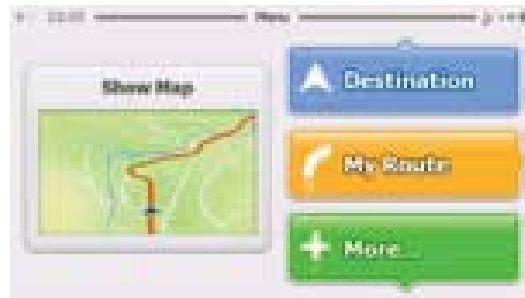

- Enter a full address or a part of an address, for example a street name without a house number or the names of two intersecting streets (page 35).
- Enter an address with postal code (page 48). This way you do not need to select the name of the settlement and the search for street names might be faster as well.
- Use a built-in Place of Interest as your destination (page 52).
- Select a location on the map with the Find on Map feature (page 65).
- Use a previously saved Favourite destination (page 66).
- Select a location from the History of previously used destinations (page 68).

## 2.1 Startup screen: the Navigation menu

The software starts with its main menu, the Navigation menu. From here you can reach all parts of the software.



You have the following options:

- Tap  to select your destination by entering an address or selecting a place of interest, a location on the map or one of your Favourite destinations. You can also look up your recent destinations from the Smart History.
- Tap  to display the route parameters and the route in its full length on the map. You can also perform route-related actions such as cancelling your route, picking route alternatives, simulating navigation or adding the destination to your Favourites. (This button remains inactive if there is no destination given.)
- Tap  to customise the way the navigation software works, watch the Demo & Tutorial, run some additional applications, or to get extra content from [www.naviextras.com](http://www.naviextras.com).
- Tap  to start navigating on the map. The button itself is a miniature live map that shows your current position, the recommended route and the surrounding map area. Tap the button to enlarge the map to the full screen.



## **2.2 Hardware buttons**

You can use your software mostly by tapping the touch screen. The device has only a few hardware buttons.





You can turn the your device on or off at any time. When the your device is switched off, your software does not calculate your GPS position and it does not update the route or the driving instructions.



When you turn the device on again, your software continues navigating as soon as the GPS receiver has determined your position.

## **2.3 Buttons and other controls on the screen**

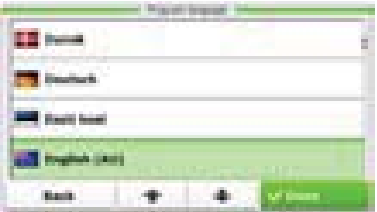
When you are using the software, you usually tap buttons on the touch screen.

You only need to confirm selections or changes if the application needs to restart, it needs to perform a major reconfiguration, or you are about to lose some of your data or settings. Otherwise, the software saves your selections and applies the new settings without confirmation as soon as you use the controls.



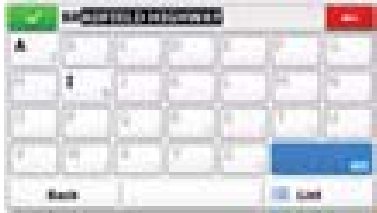

Type	Example	Description	How to use it
Button		Tap it to initiate a function, to open a new screen, or to set a parameter.	Tap it once.
Button with value		Some buttons display the current value of a field or setting. Tap the button to change the value. After the change, the new value is shown on the button.	Tap it once.
Icon		Shows status information.	Some icons also function as a button. Tap them once.
List		When you need to select from several options, they appear in a list.	Move between pages with the  and  buttons and tap the value that you want. Alternatively, grab the list anywhere and slide your finger up or down. Depending on the speed of the sliding, the list will scroll fast or slow, only a bit or till the end.

Slider		When a feature can be set to different values in a range, the software shows an indicator on a gauge that displays and sets the value.	<ul style="list-style-type: none"> <li>• Drag the handle to move the slider to its new position.</li> <li>• Tap the slider where you want the handle to appear; the thumb jumps there.</li> </ul>
Switch		When there are only two choices, a checkmark shows whether the feature is enabled.	Tap it to turn the switch on or off.
Virtual keyboard		Alphabetic and alphanumeric keyboards to enter text and numbers.	Each key is a touch screen button.

### 2.3.1 Using keyboards







You only need to enter letters or numbers when you cannot avoid it. You can type with your fingertips on the full-screen keyboards and you can switch between various keyboard layouts, for example English, Greek or numerical.



Task	Details
Switching to another keyboard layout, for example from an English keyboard to a Greek keyboard	This cannot be done when you are already using the virtual keyboard. You can do it in Regional settings (page 97).
Correcting your entry on the keyboard	Tap  to remove the unneeded character(s). Tap and hold the button to delete several characters or the entire input string.

Entering a space, for example between a first name and a family name or in multi-word street names	Tap the empty button at the bottom centre of the screen.
Entering numbers and symbols	Tap  to switch to a keyboard offering numeric and symbol characters.
Finalising the keyboard entry (accepting the suggested search result)	Tap  .
Finalising the keyboard entry (opening the list of search results)	Tap  List.
Finalising the keyboard entry (saving your input)	Tap  .
Cancelling the keyboard entry (returning to the previous screen)	Tap  .

### 2.3.2 Beyond single screen tap

You usually need to tap the screen only once. However, some useful features can be accessed with combined touch screen tapping. Those are the following:

Tasks	Instructions
Tapping and holding the screen	<p>Tap and keep pressing the following buttons to reach extra functions:</p> <ul style="list-style-type: none"> <li>• Tap and hold  on list and menu screens: the Map screen appears.</li> <li>• Tap and hold any of the , , , ,  and  buttons on the Map screen: you can rotate, tilt or scale the map continuously.</li> </ul>

Tasks	Instructions
	<ul style="list-style-type: none"> <li>• Tap and hold  on keyboard screens: you can delete several characters quickly.</li> <li>• Tap and hold  or  in long lists: you can scroll pages continuously.</li> </ul>
Gestures (drag&drop)	<p>You need to drag and drop the screen only in cases like:</p> <ul style="list-style-type: none"> <li>• Moving the handle on a slider.</li> <li>• Scrolling the list: grab the list anywhere and slide your finger up or down. Depending on the speed of the sliding, the list will scroll fast or slow, only a bit or till the end.</li> <li>• Moving the map in map browsing mode: grab the map, and move it in the desired direction.</li> <li>• Shortcut to open the Map screen: slide your finger from the bottom right corner to the bottom left corner on any screen.</li> <li>• Shortcut to open the Navigation menu: slide your finger from the top left corner to the bottom left corner on any screen.</li> </ul>

## 2.4 Map screen

### 2.4.1 Navigating on the map

The Map screen is the most frequently used screen of the software. A small live map is displayed on the startup screen, the Navigation menu, as a part of the

 button.

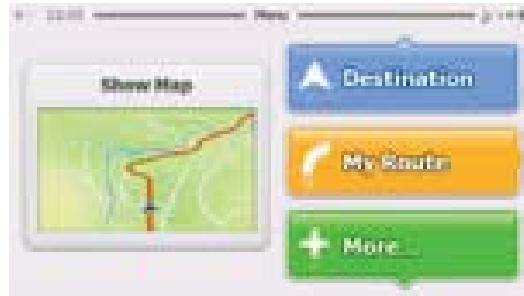

To enlarge this small map and open the Map screen, tap .

The map is displayed in black and white when there is no GPS position:



... or in full colour when the current position is available:



This map shows the current position (the Vehimarker, a blue arrow by default), the recommended route (an orange line), and the surrounding map area.

There are screen buttons and data fields on the screen to help you navigate. During navigation, the screen shows route information.

Tap the bottom left corner to see all three route data fields.

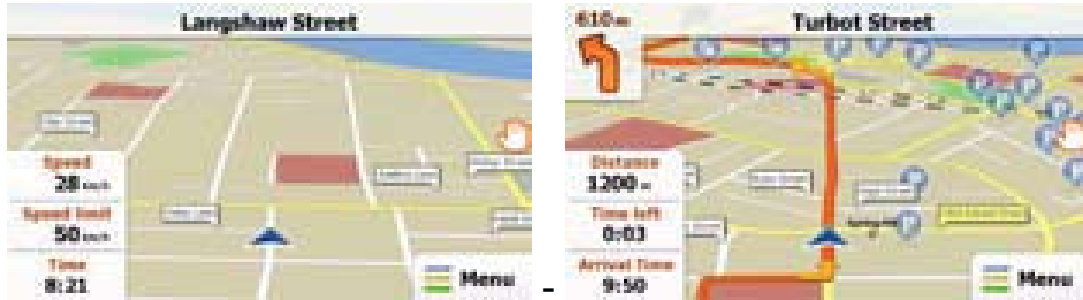

Tap any of the data fields to suppress others and display only the selected one. The data fields are different when you are navigating an active route and when you have no specified destination (the orange line is not displayed).

Data fields when cruising without a destination:

Field	Description
Speed 61 km/h	Shows your current speed given by the GPS receiver.
Speed limit 70 km/h	Shows the speed limit of the current road if the map contains it.
Time 17:11	Shows the current time corrected with time zone offset. The accurate time comes from the GPS satellites, and the time zone information comes from the map or it can be set manually in Regional settings. (The current time is always displayed in the top left corner of the high level menu screens.)

Data fields when navigating a route:

Field	Description
Distance 16.9 km	Shows the distance you need to travel on the route before reaching your final destination.

Field	Description
<b>Time left</b> <b>0:16</b>	<p>Shows the time needed to reach the final destination of the route based on information available for the remaining segments of the route.</p> <p>The calculation cannot take into account traffic jams and other possible delays.</p>
<b>Arrival Time</b> <b>17:22</b>	<p>Shows the estimated arrival time at the final destination of the route based on information available for the remaining segments of the route.</p> <p>The calculation cannot take into account traffic jams and other possible delays.</p>

## 2.4.2 Position markers

### 2.4.2.1 Vehimarker and Lock-on-Road

When your GPS position is available, the software marks your current position with the Vehimarker. By default, this marker is a blue arrow, but you can change this icon in Settings.

The exact location of the Vehimarker depends on the vehicle type used for route calculation. The vehicle type can be selected in Route settings (page 92).

- If you choose pedestrian: The Vehimarker is at your exact GPS position. The direction of the icon shows your current heading.



- If you choose any of the vehicles: The Vehimarker may not show your exact GPS position and heading. If roads are near, it is aligned to the nearest road to suppress GPS position errors, and the direction of the icon is aligned to the direction of the road.

### 2.4.2.2 Selected location (Cursor) in Find on Map

If you select a location on the map in Find on Map (page 65), the Cursor appears at the selected point on the map. The Cursor is displayed with a radiating red dot (  ) to make it visible at all zoom levels.

The location of the Cursor can be used as the destination of the route.

## 2.4.3 Objects on the map

### 2.4.3.1 Streets and roads

The software shows the streets in a way that is similar to how the paper road maps show them. Their width and colours correspond to their importance: you can easily tell a motorway from a small street.

### 2.4.3.2 Turn Preview and next street

When navigating a route, the top section of the Map screen shows information about the next route event (manoeuvre) and the next street or the next city/town.

















There is a field in the top left corner that displays the next manoeuvre. Both the type of the event (turn, roundabout, exiting motorway, etc.) and its distance from the current position is displayed.

A smaller icon shows the type of the second next manoeuvre if it is near the first one. Otherwise, only the next manoeuvre is displayed.



Most of these icons are very intuitive. The following table lists some of the frequently shown route events. The same symbols are used in both fields:

Icon	Description
	Turn left.
	Turn right.
	Turn back.
	Bear right.
	Turn sharp left.
	Keep left.
	Continue straight in the intersection.
 , 	Enter roundabout. The layout of the roundabout and the number of the exit is shown only for the next turn.
	Enter motorway.
	Exit motorway.
	Board ferry.

Icon	Description
	Leave ferry.
	Approaching the destination.

### 2.4.3.3 Lane information and Signposts

When navigating on multilane roads, it is important to take the appropriate lane in order to follow the recommended route. If lane information is available in the map data, the software displays the lanes and their directions using small arrows at the bottom of the map. Highlighted arrows represent the lanes you need to take.

Where there is additional information available, signposts substitute arrows. Signposts are displayed at the top of the map. The colour and style of the signposts are similar to the real ones you can see above road or by the roadside. They show the available destinations and the number of the road the lane leads to.

All signposts look similar when cruising (when there is no recommended route). When navigating a route, only that signpost is displayed in vivid colours that points to the lane(s) to be taken; all others are darker.

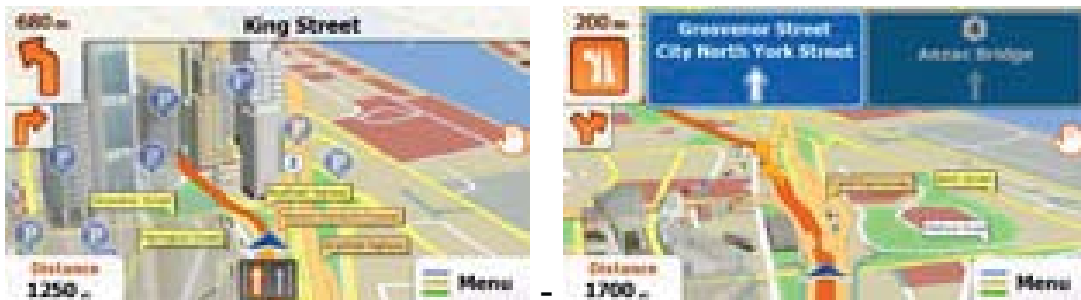

### 2.4.3.4 3D object types

Your software supports the following 3D object types:

Type	Description
3D terrain	3D terrain map data shows changes in terrain, elevations or depressions in the land when you view the map in 2D, and use it to plot the route map in 3D when you navigate. Hills and mountains are shown in the background of the 3D map, and illustrated by colour and shading on the 2D map.
Elevated roads	Complex intersections and vertically isolated roads (such as overpasses or bridges) are displayed in 3D.
3D landmarks	Landmarks are 3D artistic or block representations of prominent or well-known objects.  3D landmarks may not be part of the original software or they may need additional activation. They are only available in selected cities and countries. Check <a href="http://www.naviextras.com">www.naviextras.com</a> for details.
3D buildings	Block representation of full 3D city building data containing actual building size and position on the map. At time of print building data is limited to CBD of Melbourne and Sydney. This coverage is intended to expand in future data releases.

#### 2.4.3.5 Elements of the active route

Your software shows the route in the following way:

Symbol	Name	Description
	Current GPS position and Start point	<p>Your current position displayed on the map.</p> <ul style="list-style-type: none"> <li>• In pedestrian mode it is the exact GPS position.</li> <li>• If a vehicle is selected for route calculation and roads are near, the symbol is snapped onto the nearest road.</li> </ul> <p>Normally if GPS position is available, the route starts from the current position. If there is no valid GPS position, your software uses the last known position as the start point.</p>





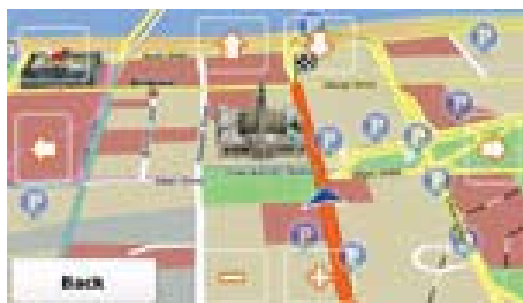

	Destination (end point)	The last point of the route.
	Map colour	The map is vivid and colourful when GPS position is available. Whenever the current position is not available, the map turns grey. The software however may still move the Vehimarker to show a possible but not confirmed position.
	Route colour	The route always stands out with its colour on the map, both in daytime and in night colour mode.
	Streets and roads that are excluded from the navigation	You can choose whether you want to use or avoid certain road types (page 66). However, when your software cannot avoid such roads, the route will include them and it will show them in a colour that is different from the route colour.

#### 2.4.4 Manipulating the map

To browse the map during navigation, tap . The map stops following the current position (the Vehimarker, a blue arrow by default, is not locked in a fix position on the screen any more) and control buttons appear to help you modify the map view.



Action	Button(s)	Description
Moving the map with drag&drop	No buttons	You can move the map in any direction: tap and hold the map, and move your finger towards the direction you want to move the map.

Action	Button(s)	Description
Zooming in and out		<p>Changes how much of the map is displayed on the screen.</p> <p>your software uses high-quality vector maps that let you examine the map at various zoom levels, always with optimised content. It always displays street names and other text with the same font size, never upside-down, and you only see the streets and objects that you need.</p> <p>Map scaling has a limit in 3D map view mode. If you zoom out further, the map switches to 2D view mode. Tap the button once to modify the view in large steps, or tap and hold the button to modify it continuously and smoothly.</p>
Tilting up and down		<p>Changes the vertical view angle of the map in 3D mode.</p> <p>Tap the button once to modify the view in large steps, or tap and hold the button to modify it continuously and smoothly.</p>
Rotating left and right		<p>Changes the horizontal view angle of the map.</p> <p>Tap the button once to modify the view in large steps, or tap and hold the button to modify it continuously and smoothly.</p>
Compass in 2D map view mode		<p>The direction of the compass shows North. Tap the button to switch to North-up view, then tap again to rotate the map in the previous direction.</p>
Compass in 3D map view mode		<p>The direction of the compass shows North. Tap the button to switch to North-up view, then tap again to rotate the map in the previous direction.</p>
Return to normal navigation		<p>Tap this button to move the map back to the current GPS position. If the map has been rotated, automatic map rotation is also re-enabled.</p>

## 2.4.5 Quick menu

The Quick menu is a selection of controls that are frequently needed during navigation. It can be opened directly from the Map screen by tapping the map.

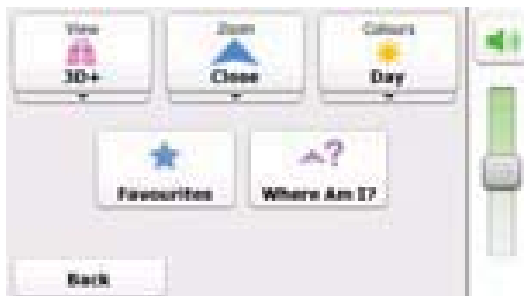

Buttons in the top row: These buttons are switches. Their current value is displayed on the button. Tap any of the buttons to see all values.

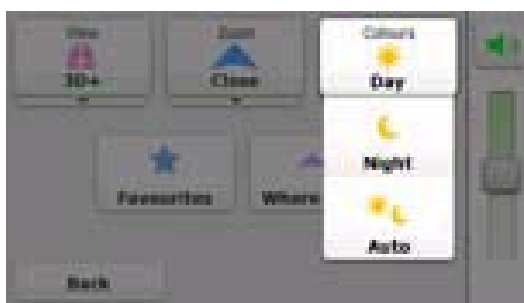









Now tap any of the values and your selection takes immediate effect. The Map screen returns automatically.

Buttons in the middle row: These buttons open new screens. Work on those screens, and when you get back here, tap  to return to the Map screen or tap and hold  on any screen to return to the Map screen directly.







The buttons and their values on this screen are the following:

Button	Function
<input type="button" value="Back"/>	If you do not use the switches in the top row, you need to use this button to return to the Map screen.
Master Volume slider	Adjusts the sound volume of the device. All sounds of the application are affected.

	<p>Use the switch to mute all sounds of the device and then to re-enable them again.</p>
	<p>The map can be displayed in a perspective view (3D) or in a top-down view (2D), and in 3D mode buildings can be displayed on the map. Selectable values:</p> <p> : The map is displayed in 3D (perspective) view. If 3D building data is installed in the software buildings are visible on the map.</p> <p> : The map is displayed in 3D (perspective) view. Buildings are suppressed.</p> <p> : The map is displayed in 2D (top-down) view.</p>

Button	Function
	<p>The zoom level of the map can be set. Smart Zoom continuously zooms the map in and out. This is a reference to the average zoom level. Selectable values:</p> <p> : The default zoom level. Smart Zoom modifies the zoom and tilt levels to an optimal view for the current route situation.</p> <p> : The zoom level is higher than the normal. All map elements are displayed in large, a part of the surrounding area is not visible.</p> <p> : The zoom level is lower than the normal. Map elements become smaller, but more of the surrounding area is shown.</p>









	<p>Switches between the daytime and night colour themes. Selectable values:</p> <p> : The map and the menu screens are displayed in daytime colours.</p> <p> : The map and the menu screens are displayed in night colours.</p> <p> : This enables your software to switch automatically between the daytime and the night colour themes based on the current time and GPS position a few minutes before sunrise, when the sky has already turned bright, and a few minutes after sunset, before it becomes dark.</p>
	<p>This button opens the list of Favourite destinations to select a new route destination. This list can also be accessed from the Destination menu.</p>
	<p>This button opens a special screen with information about the current position and a button to search for nearby emergency or roadside assistance. For details, see the next chapter.</p>

## 2.4.6 Checking the details of the current position (Where Am I?)

Opened from the Quick menu, this screen contains information about the current position (or about the last known position if GPS reception is not available) and a button to search for useful Places nearby.





Information on this screen:

-  : Latitude and Longitude (coordinates of the current position in WGS84 format).
-  : Altitude (elevation information coming from the GPS receiver - often inaccurate).
-  : Address details (when available) of the current position.
-  : House number on the left.
-  : House number on the right.
-  : Shows whether the position is current, or the time left since it was last updated.

Besides these pieces of information, you can search for assistance near your current position.

Tap  to open a new screen for the Quick search:

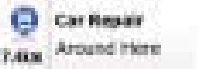
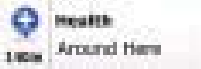
The following services can be searched around the current position or the last known position:

-  : Car repair and roadside assistance services
-  : Medical and emergency services
-  : Police stations
-  : Cash dispensers

Tap any of the buttons, select a Place from the list, and navigate to it.

## 3 Navigating

---

You can set up your route in different ways:

- If you need a route for immediate navigation, you can select the destination and start navigating to it right away (normal navigation).
- You can also plan a route independently of your current GPS position or even without GPS reception (to achieve this, you need to turn off the GPS receiver and set a new starting point in the Settings menu - see page 72).

### 3.1 Selecting the destination of a route

The software offers you several ways of choosing your destination:

- Enter a full address or a part of an address, for example a street name without a house number or the names of two intersecting streets (page 36). If you only know the street address and not the city/town then see the tip on how to select ALL cities within the state (page 37).
- Enter an address with postal code (page 48). This way you do not need to select the name of the settlement and the search for street names might be faster as well.
- Use a built-in Place of Interest as your destination (page 52).
- Select a location on the map with the Find on Map feature (page 66).
- Use a previously saved Favourite destination (page 66).
- Select a location from the History of previously used destinations (page 68).

#### 3.1.1 Entering an address or part of an address



If you know at least a part of the address, it is the quickest way to select the destination of the route.

Using the same screen, you can find an address by entering:

- the exact address, including house number
- the centre of a city/town
- an intersection
- the midpoint of a street
- any of the above, starting the search with the postal code (page 48)

### 3.1.1.1 Entering an address

To enter an address as the destination, do as follows:

1. If you are on the Map screen, tap  to return to the Navigation menu.
2. In the Navigation menu, tap the following buttons: , .
3. By default, the software proposes the country, state and settlement where you are. If needed, tap the button with the name of the country, enter the first few letters of the country name on the keyboard, and select a different one from the list. If you select a new country, you also need to select the state, or select the name of the country where it stands without a state to search for an address in all its states.



4. If you need to change the state, tap the button with the name of the state, enter the first few letters of the state name, and select a different state from the list.





5. If needed, select a new city/town (see below Tip to select ALL cities):

1. Tap the button with the name of the city/town, or if you have changed the country/state, tap **<City Name>** .

2. Start entering the name of the city/town on the keyboard.

3. Find the city/town you need:

- The most likely city/town name is always shown in the input field. To accept it, tap  .
- If the desired name does not show up, the names that match the string appear in a list after entering a couple of characters (to open the list of results before it appears automatically, tap  **List** ). Select the city/town from the list.





To search ALL cities within a state, do not enter a city name but instead tap  **List** .

6. Enter the street name:

1. Tap **<Street Name>** .

2. Start entering the street name on the keyboard.

3. Find the street you need:

- The most likely street name is always shown in the input field. To accept it, tap .
- If the desired name does not show up, the names that match the string appear in a list after entering a couple of characters (to open the list of results before it appears automatically, tap  **List** ). Select the street from the list.



7. Enter the house number:

1. Tap **<House Number>** .

2. Enter the house number on the keyboard. (To enter letters, tap  **Alt** ).

3. Tap  **Done** to finish entering the address. (If the entered house number cannot be found, the midpoint of the street is selected as the destination.)



8. (optional) There are long roads where house numbering is restarted at some point. This way the same house number can appear twice or even more times on the

same road. If this is the case, a list appears after entering the house number. You need to select the appropriate address by the district/suburb information.



9. After a short summary of the route parameters, the map appears with the selected destination in the middle. The route is automatically calculated. Tap or to modify route parameters, or tap and start your journey.

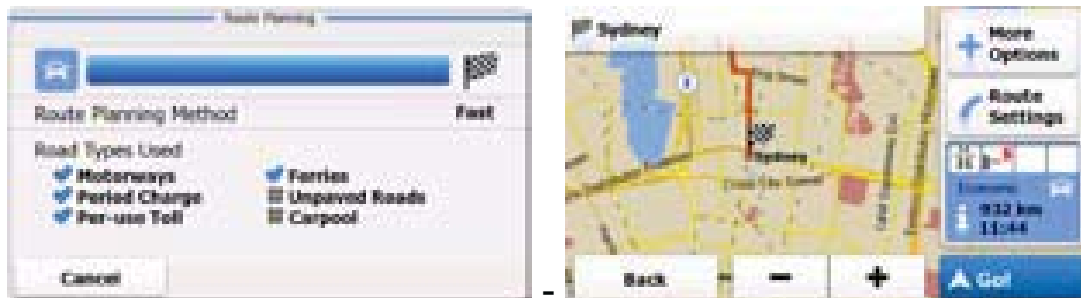

**TIP**

If you know that you will use this destination frequently, before tapping , put the destination on the list of your Favourites first: tap and then , and save the location. The map with the destination returns automatically. Now you can start your journey.

### 3.1.1.2 Entering the midpoint of a street as the destination

You can navigate to the midpoint of a street if the house number is not available:

1. If you are on the Map screen, tap to return to the Navigation menu.

2. In the Navigation menu, tap the following buttons: , .

3. By default, the software proposes the country, state and settlement where you are. If needed, tap the button with the name of the country, enter the first few letters of the country name on the keyboard, and select a different one from the list. If you select a new country, you also need to select the state, or select the name of the country where it stands without a state to search for an address in all its states.



4. If you need to change the state, tap the button with the name of the state, enter the first few letters of the state name, and and select a different state from the list.



5. If needed, select a new city/town:

1. Tap the button with the name of the city/town, or if you have changed the country/state, tap **<City Name>** .

2. Start entering the name of the city/town on the keyboard.

3. Find the city/town you need:

- The most likely city/town name is always shown in the input field. To accept it, tap  .
- If the desired name does not show up, the names that match the string





appear in a list after entering a couple of characters (to open the list of results before it appears automatically, tap  List ). Select the city/town from the list.



6. Enter the street name:



### <Street Name>

1. Tap .
2. Start entering the street name on the keyboard.
3. Find the street you need:
  - The most likely street name is always shown in the input field. To accept it, tap .
  - If the desired name does not show up, the names that match the string appear in a list after entering a couple of characters (to open the list of results before it appears automatically, tap  List ). Select the street from the list.



7. Instead of entering the house number, tap . The midpoint of the street is selected as the destination.



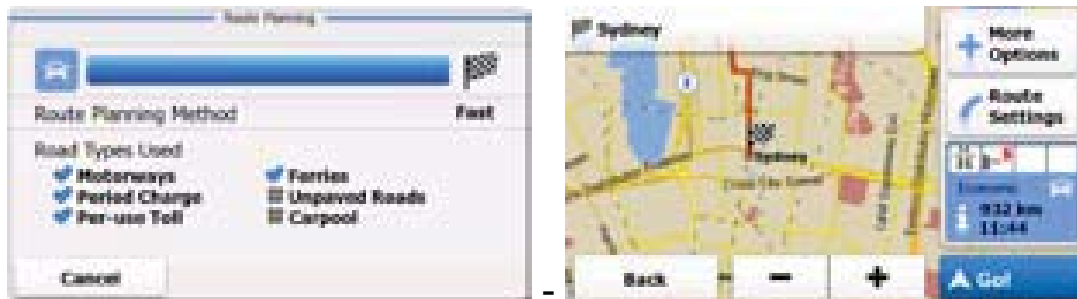

8. After a short summary of the route parameters, the map appears with the selected destination in the middle. The route is automatically calculated. Tap  **More Options** or  **Route Settings** to modify route parameters, or tap  and start your journey.



### 3.1.1.3 Selecting an intersection as the destination

To enter an address as the destination, do as follows:

1. If you are on the Map screen, tap  **Menu** to return to the Navigation menu.
2. In the Navigation menu, tap the following buttons: , .
3. By default, the software proposes the country, state and settlement where you are. If needed, tap the button with the name of the country, enter the first few letters of the country name on the keyboard, and select a different one from the list. If you select a new country, you also need to select the state, or select the name of the country where it stands without a state to search for an address in all its states.



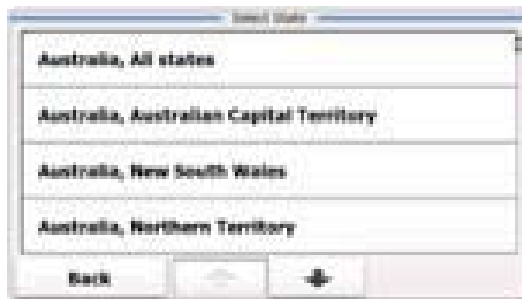

4. If you need to change the state, tap the button with the name of the state, enter the first few letters of the state name, and select a different state from the list.





5. If needed, select a new city/town:

1. Tap the button with the name of the city/town, or if you have changed the country/state, tap **<City Name>**.
2. Start entering the name of the city/town on the keyboard.
3. Find the city/town you need:

- The most likely city/town name is always shown in the input field. To accept it, tap .
- If the desired name does not show up, the names that match the string appear in a list after entering a couple of characters (to open the list of results before it appears automatically, tap  **List** ). Select the city/town from the list.



6. Enter the street name:

1. Tap **<Street Name>** .
2. Start entering the street name on the keyboard.
3. Find the street you need:
  - The most likely street name is always shown in the input field. To accept it, tap  .
  - If the desired name does not show up, the names that match the string appear in a list after entering a couple of characters (to open the list of results before it appears automatically, tap  **List** ). Select the street from the list.

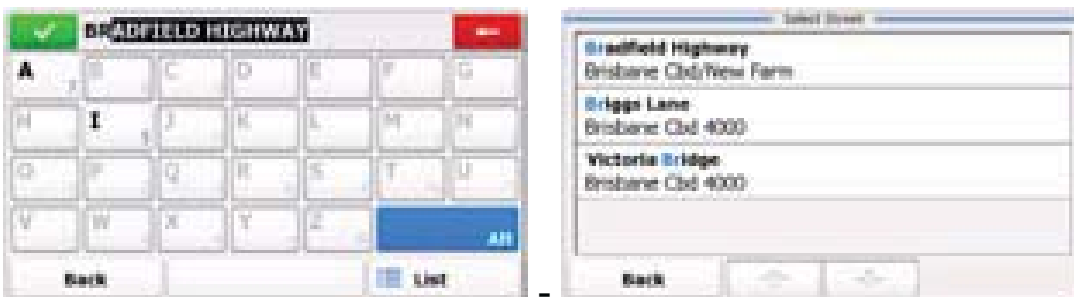



7. Enter the intersecting street name:

1. Tap **<Intersecting Street>** .

- If only a few intersecting streets exist, their list appears immediately.
- In case of a longer street, a keyboard screen appears. Start entering the name of the intersecting street on the keyboard. As soon as the street names that match the entered string can be shown on one screen, their list appears automatically. Select from the list.



8. After a short summary of the route parameters, the map appears with the selected destination in the middle. The route is automatically calculated. Tap  **More Options** or  **Route Settings** to modify route parameters, or tap  **Go!** and start your journey.

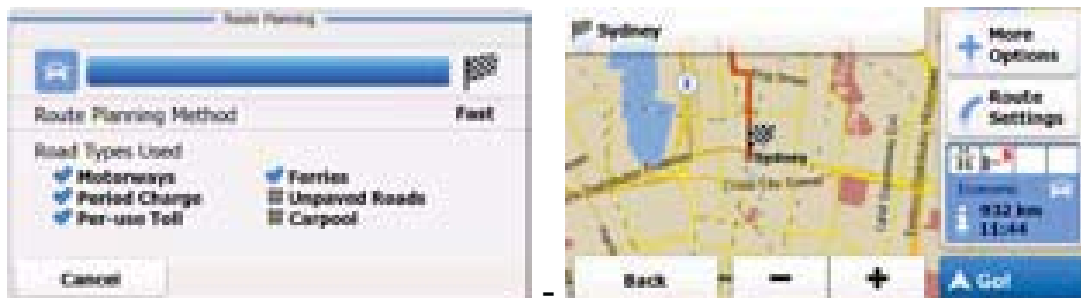

### 3.1.1.4 Selecting a city/town centre as the destination

The city/town centre is not the geometric centre of the settlement but an arbitrary point the map creators have chosen. In towns and villages, it is usually the most important intersection; in larger cities, it is one of the important intersections.

1. If you are on the Map screen, tap  **Menu** to return to the Navigation menu.

2. In the Navigation menu, tap the following buttons:  **Destination** ,  **Find address** .

3. By default, the software proposes the country, state and settlement where you are. If needed, tap the button with the name of the country, enter the first few letters of the country name on the keyboard, and select a different one from the list. If you select a new country, you also need to select the state, or select the name of the country where it stands without a state to search for an address in all its states.



4. If you need to change the state, tap the button with the name of the state, enter the first few letters of the state name, and and select a different state from the list.





5. If needed, select a new city/town:
  1. Tap the button with the name of the city/town, or if you have changed the country/state, tap `<City Name>` .
  2. Start entering the name of the city/town on the keyboard.
  3. Find the city/town you need:
    - The most likely city/town name is always shown in the input field. To accept it, tap  .

- If the desired name does not show up, the names that match the string appear in a list after entering a couple of characters (to open the list of results before it appears automatically, tap  List ). Select the city/town from the list.



6. Instead of entering the street name, tap . This way the centre of the displayed city/town becomes the destination of the route.



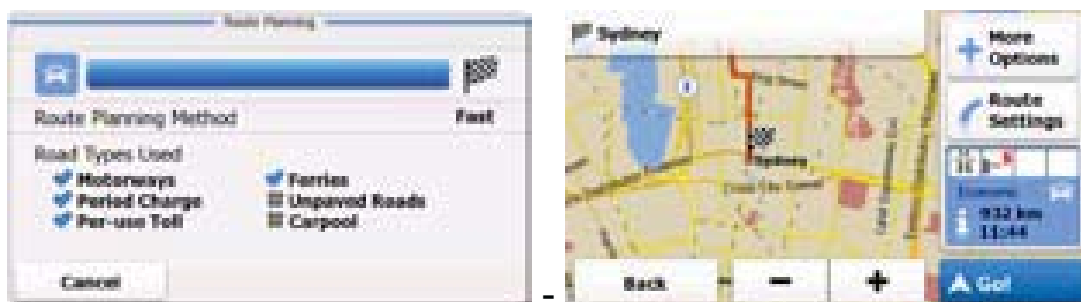

7. After a short summary of the route parameters, the map appears with the selected destination in the middle. The route is automatically calculated. Tap  or  to modify route parameters, or tap  and start your journey.



### 3.1.1.5 Entering an address with a postal code

All of the above address searching possibilities can be performed with entering the postal code instead of the settlement name. Find below an example with a full address:

1. If you are on the Map screen, tap  to return to the Navigation menu.

2. In the Navigation menu, tap the following buttons: , .

3. By default, the software proposes the country, state and settlement where you are. If needed, tap the button with the name of the country, enter the first few letters of the country name on the keyboard, and select a different one from the list. If you select a new country, you also need to select the state, or select the name of the country where it stands without a state to search for an address in all its states.





4. If you need to change the state, tap the button with the name of the state, enter the first few letters of the state name, and select a different state from the list.





5. Enter a new city/town using its postal code:



1. Tap the button with the name of the city/town, or if you have changed the country/state, tap `<City Name>` .
2. Tap  to open the numeric keypad.
3. Start entering the postal code.
4. Find the city/town you need:
  - The most likely postal code is always shown in the input field. To accept it, tap  .
  - If the desired number does not show up, open the list of results by tapping  . Select the postal code from the list.



6. Enter the street name:

1. Tap `<Street Name>` .
2. Start entering the street name on the keyboard.
3. Find the street you need:
  - The most likely street name is always shown in the input field. To accept it, tap  .
  - If the desired name does not show up, the names that match the string appear in a list after entering a couple of characters (to open the list of results before it appears automatically, tap  ). Select the street from the list.



7. Enter the house number:



1. Tap **<House Number>**.
2. Enter the house number on the keyboard. (To enter letters, tap **Alt**).
3. Tap **Done** to finish entering the address. (If the entered house number cannot be found, the midpoint of the street is selected as the destination.)

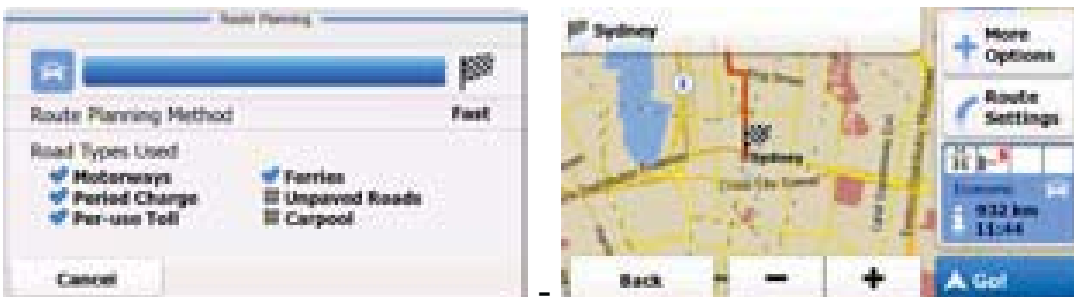

8. After a short summary of the route parameters, the map appears with the selected destination in the middle. The route is automatically calculated. Tap **+ More Options** or **Route Settings** to modify route parameters, or tap **Go!** and start your journey.



### 3.1.1.6 Tips on entering addresses quickly

- When you are entering the name of a city/town or a street:
  - Only those letters are offered on the keyboard that appear in possible search results. All other characters are greyed out.
  - As you are typing, the most likely result is always displayed in the input field. If the guess is correct, tap  to select it.
  - After entering a couple of letters, tap  List to list the items that contain the specified letters.
- You can speed up finding an intersection:
  - Search first for the street with a less common or less usual name; fewer letters are enough to find it.
  - If one of the streets is shorter, search for that one first. You can then find the second one faster.
- You can search for both the type and the name of a road. If the same word appears in several names, for example in the name of streets, roads and avenues, you can obtain the result faster if you enter the first letter of the street type: For example, enter 'PI A' to obtain Pine Avenue and skip all Pine Streets and Pickwick Roads.
- You can also search in postal codes. This is useful when a street name is common and it is used in several districts of a city.

### 3.1.2 Selecting the destination from the Places of Interest

You can select your destination from the Places of Interest included with your software.

Using the same screen, you can find a Place in different ways:

- with the Quick search feature, you can find frequently searched types of Places with only a few screen taps
- you can search for a Place by its name
- you can search for a Place by its category

In addition, you can search for special services from the 'Where Am I?' screen.

#### 3.1.2.1 Selecting the destination from the Places of Interest with Quick search

The Quick search feature lets you quickly find the most frequently selected types of Places.

1. If you are on the Map screen, tap  to return to the Navigation menu.

2. In the Navigation menu, tap the following buttons: , .



3. The Quick search categories appear:

•  :

- If an active route exists, petrol stations are searched along the route.

- If there is no active route (destination is not selected), they are searched around the current position.
- If the current position is not available either (no GPS signal), they are searched around the last known position.



- If an active route exists, restaurants are searched along the route.
- If there is no active route (destination is not selected), they are searched around the current position.
- If the current position is not available either (no GPS signal), they are searched around the last known position.



- If an active route exists, parking lots are searched around the destination of the route.
- If there is no active route (destination is not selected), they are searched around the current position.
- If the current position is not available either (no GPS signal), they are searched around the last known position.



- If an active route exists, accommodation is searched around the destination of the route.
- If there is no active route (destination is not selected), they are searched around the current position.
- If the current position is not available either (no GPS signal), they are searched around the last known position.

4. Tap any of the quick search buttons to get an instant list of Places.







5. The Places in the list are ordered by their distance from the current position, from the destination or by the length of the necessary detour. Normal Places are displayed with their blue category icon only (📍), while Places with extra details (so called "Rich POIs") are marked with the logo of their data source (📍📄). Tap any of the list items to see its basic details.

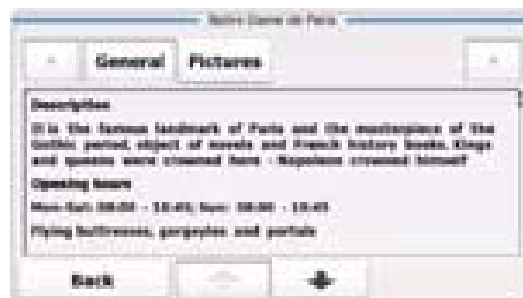

6. (optional) If the selected Place is a Rich POI, you can tap **More Details** to display additional information. Then tap **Back** to return to the basic details.



7. Tap  to select the displayed Place of Interest as the destination of the route.
8. After a short summary of the route parameters, the map appears with the selected destination in the middle. The route is automatically calculated. Tap  or  to modify route parameters, or tap  and start your journey.

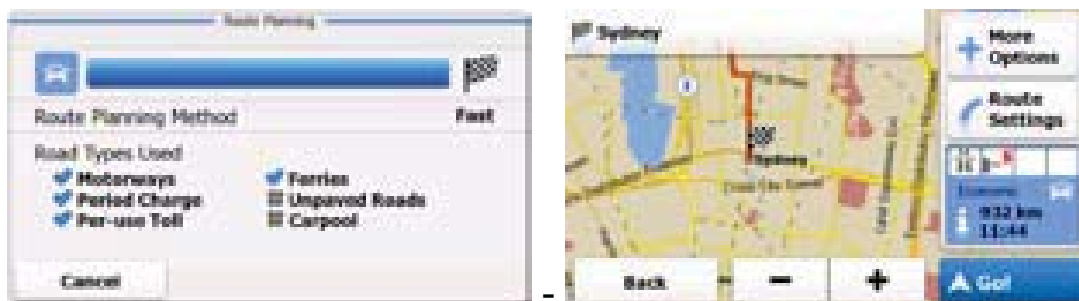

### 3.1.2.2 Selecting the destination from other Places of Interest by name

You can search for Places of Interest by their names.

1. If you are on the Map screen, tap  to return to the Navigation menu.

2. In the Navigation menu, tap the following buttons: , .

3. The Quick search categories appear. Tap .

4. Select the area where the Place should be searched for:

- Tap  to search around the current position or if it is not available, around the last know position. (The result list will be ordered by the distance from this position.)

- Tap **In a City** to search for a place within a selected city or town. (The result list will be ordered by the distance from the centre of the selected city/ town.)
- Tap **Around Destination** to search for a place around the destination of the active route. (The result list will be ordered by the distance from the destination.)
- Tap **Along Route** to search along the active route, and not around a given point. This is useful when you search for a later stopover that results in a minimal detour only, such as searching for upcoming petrol stations or restaurants. (The result list will be ordered by the length of the necessary detour.)



5. (optional) If you have selected **In a City**, select the city/town, then tap **Select**.

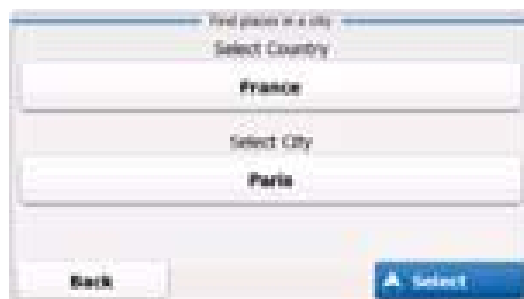

6. Tap **Find by Name**.







7. Using the keyboard, start entering the name of the Place.

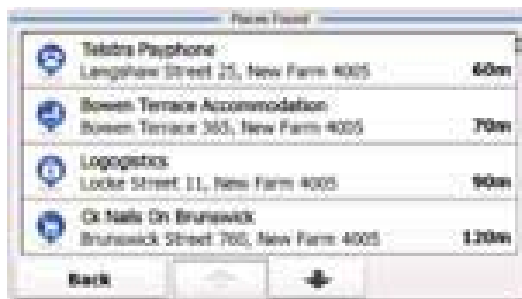

8. After entering a few letters, tap to open the list of Places with names similar to the entered characters.



9. The Places in the list are ordered by their distance from the current position, from the destination, from the centre of the selected city/town or by the length of the necessary detour. Normal Places are displayed with their blue category icon only (📍), while Places with extra details (so called “Rich POIs”) are marked with the logo of their data source (📍📌). If needed, tap  to browse the list. Tap any of the list items to see its basic details.



10. (optional) If the selected Place is a Rich POI, you can tap **More Details** to display additional information. Then tap **Back** to return to the basic details.
11. Tap **Select** to select the displayed Place of Interest as the destination of the route.
12. After a short summary of the route parameters, the map appears with the selected destination in the middle. The route is automatically calculated. Tap **+ More Options** or **Route Settings** to modify route parameters, or tap **Go!** and start your journey.

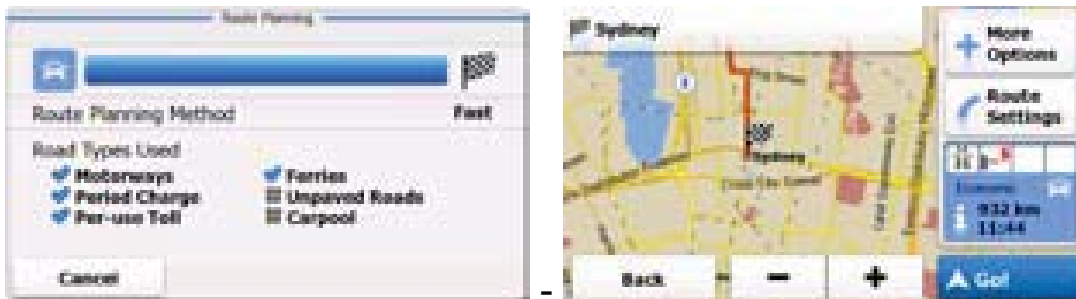

### 3.1.2.3 Selecting the destination from other Places of Interest by category

You can search for Places of Interest by their categories and subcategories.

1. If you are on the Map screen, tap **Menu** to return to the Navigation menu.





2. In the Navigation menu, tap the following buttons:



3. The Quick search categories appear. Tap



4. Select the area around which the Place should be searched for:

- Tap  to search around the current position or if it is not available, around the last known position. (The result list will be ordered by the distance from this position.)
- Tap  to search for a place within a selected city or town. (The result list will be ordered by the distance from the centre of the selected city/town.)
- Tap  to search for a place around the destination of the active route. (The result list will be ordered by the distance from the destination.)
- Tap  to search along the active route, and not around a given point. This is useful when you search for a later stopover that results in a minimal detour only, such as searching for upcoming petrol stations or restaurants. (The result list will be ordered by the length of the necessary detour.)



5. (optional) If you have selected , select the city/town, then tap



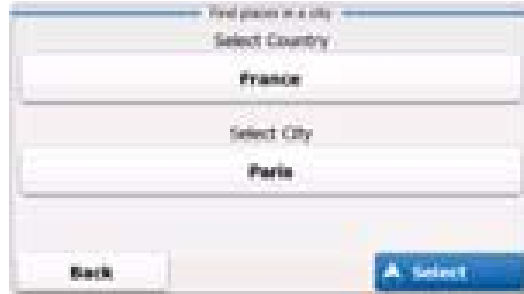

6. Tap **Find by Category**.



7. Select one of the main Place categories (e.g. Accommodation) or tap

**Show All**

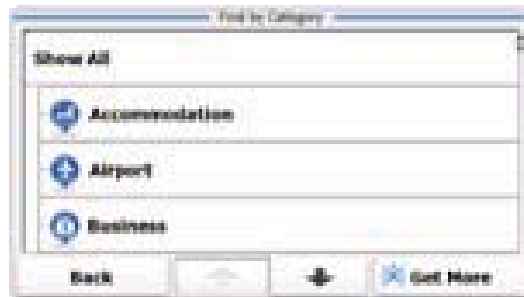

8. Select one of the main Place subcategories (e.g. Hotel or Motel) or tap

**Show All**

to list all Places in the selected main category around the selected location or along the route.

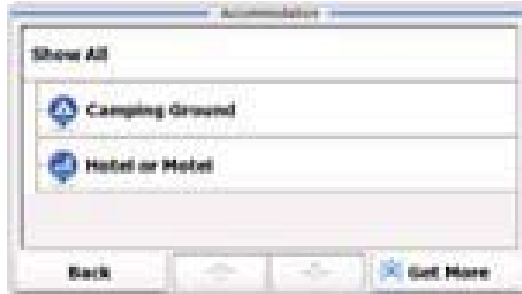

9. Finally, the results appear in a list.

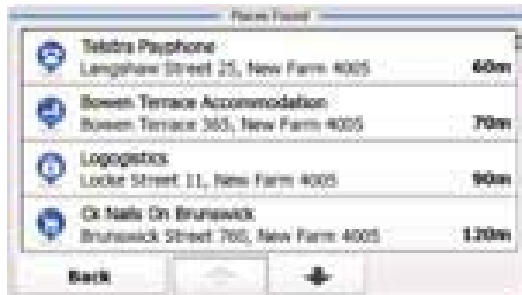



10. The Places in the list are ordered by their distance from the current position, from the destination, from the centre of the selected city/town or by the length of the necessary detour. Normal Places are displayed with their blue category icon only (📍), while Places with extra details (so called “Rich POIs”) are marked with the logo of their data source (📍📌). If needed, tap to browse the list. Tap any of the list items to see its basic details.

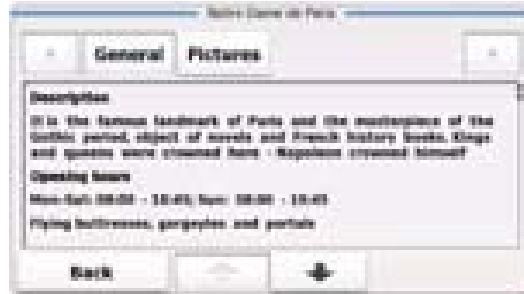

11. (optional) If the selected Place is a rich POI, you can tap **More Details** to display additional information. Then tap **Back** to return to the basic details.



12. Tap  to select the displayed Place of Interest as the destination of the route.

13. After a short summary of the route parameters, the map appears with the selected destination in the middle. The route is automatically calculated. Tap  or  to modify route parameters, or tap  and start your journey.

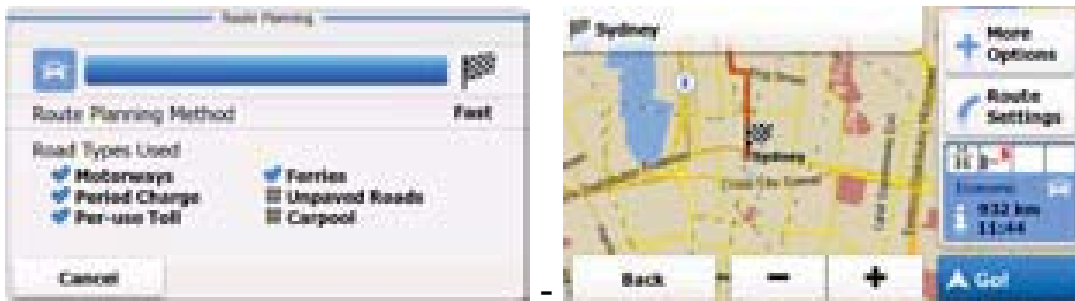

### 3.1.2.4 Selecting nearby assistance from 'Where Am I?'

You can quickly search for nearby assistance from the 'Where Am I?' screen.



1. On the Map screen, tap the map anywhere to open the Quick menu.



2. Tap , and then .



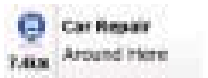
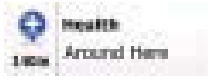

3. The Quick search categories appear, all for searching around the current position (or around the last known position if the current position is not available):

-  : Car repair and roadside assistance services
-  : Medical and emergency services
-  : Police stations
-  : Cash dispensers

4. Tap any of the quick search buttons to get an instant list of that type of Places.



5. The Places in the list are ordered by their distance from the current position, from the destination or by the size of the needed detour. Normal Places are displayed with their blue category icon only () , while Places with extra details (so called rich POIs) are marked with the logo of their data source (). Tap any of the list items to see its basic details.



6. (optional) If the selected Place is a 'rich POI', you can tap **More Details** to display additional information. Then tap **Back** to return to the basic details.

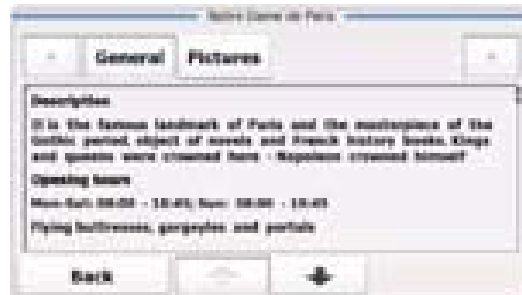

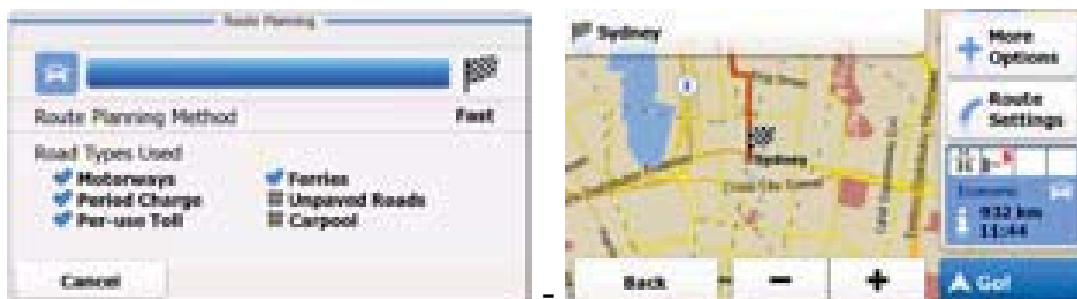

7. Tap **Select** to select the displayed Place of Interest as the destination of the route.

8. After a short summary of the route parameters, the map appears with the selected destination in the middle. The route is automatically calculated. Tap **+ More Options** or **Route Settings** to modify route parameters, or tap **Go!** and start your journey.





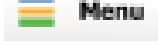



### 3.1.3 Selecting a map location as the destination

1. If you are on the Map screen, tap  to return to the Navigation menu.
2. In the Navigation menu, tap the following buttons:  ,  .
3. Locate your destination on the map: move and scale the map as needed.



4. Tap the location that you want to select as your destination. The Cursor (  ) appears.
5. Tap  to select the displayed Place of Interest as the destination of the route.
6. After a short summary of the route parameters, the map appears with the selected destination in the middle. The route is automatically calculated. Tap  or  to modify route parameters, or tap  and start your journey.

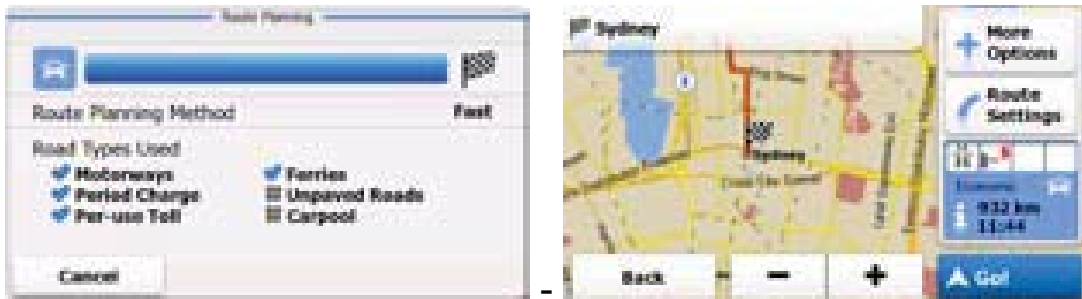

### 3.1.4 Selecting the destination from your Favourites

You can select a location that you have already saved as a Favourite to be your destination. Adding a location to the list of Favourite destinations is described on page 82.



1. Access the list of Favourites:

- If you are on the Map screen, tap the map to open the Quick menu.
- If you are in the Navigation menu, tap  .

2. Tap  . The list of Favourite destinations is displayed.



3. Select the Favourite that you want to set as your destination. If necessary, move between pages with  to see more of the list.

4. After a short summary of the route parameters, the map appears with the selected destination in the middle. The route is automatically calculated. Tap  or  to modify route parameters, or tap  and start your journey.

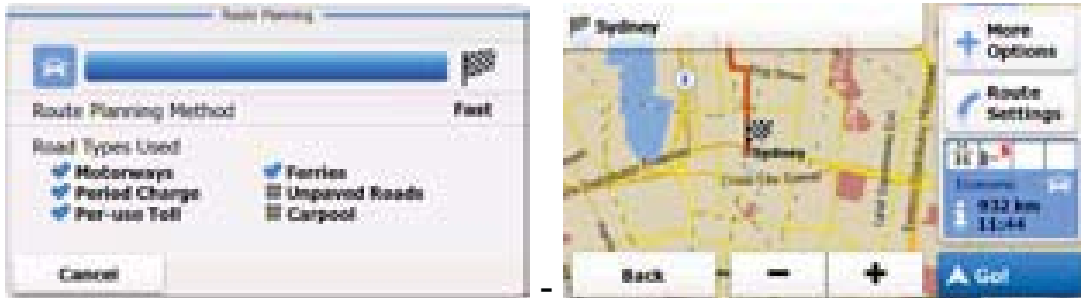

### 3.1.5 Selecting the most likely destination (Smart History)



The destinations that you have set earlier appear in the History list. One of those recent destinations is shown in the Destination menu for easy access. Smart History offers this location based upon your navigation habits, using parameters like the current time of day, the day of week, and the current location. The more you use the navigation software, the better it can guess your desired destination.

1. If you are on the Map screen, tap  **Menu** to return to the Navigation menu.

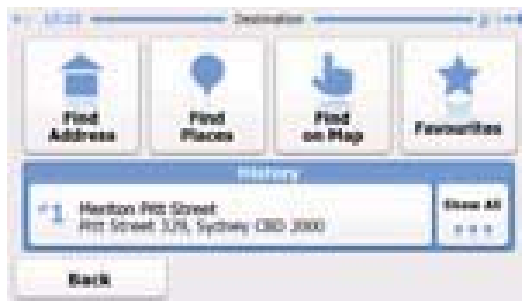
2. In the Navigation menu, tap  .



3. Tap the  destination in the History field.

4. After a short summary of the route parameters, the map appears with the selected destination in the middle. The route is automatically calculated. Tap  **More Options** or  **Route Settings** to modify route parameters, or tap  **Go!** and start your journey.

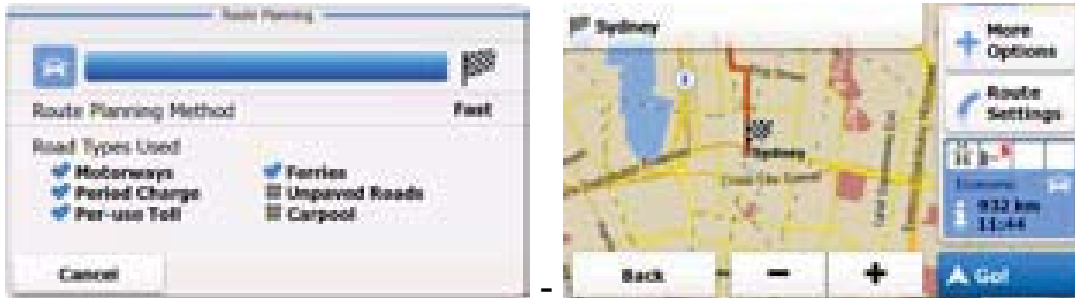

### 3.1.6 Selecting the destination from the History

The destinations that you have set earlier appear in the History.

1. If you are on the Map screen, tap  **Menu** to return to the Navigation menu.

2. In the Navigation menu, tap  .

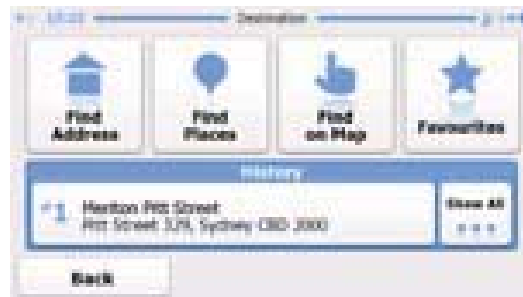



3. Tap .

4. The list of recent destinations appear. Smart History promotes three destinations to the first page based on your previous routes (most likely destinations). The rest of the destinations are ordered by time they were last selected. If necessary, scroll the list to see earlier destinations.



5. Select a destination from the list.

6. After a short summary of the route parameters, the map appears with the selected destination in the middle. The route is automatically calculated. Tap  or  to modify route parameters, or tap  and start your journey.

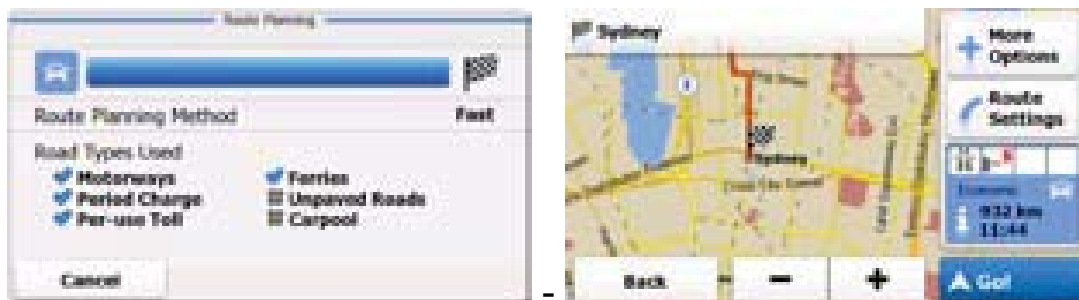

### 3.2 Viewing the entire route on the map

It is easy to get a map overview of the active route. Do as follows:

1. If you are on the Map screen, tap  to return to the Navigation menu.
2. In the Navigation menu, tap . The active route is displayed in its full length on the map together with additional information and controls.

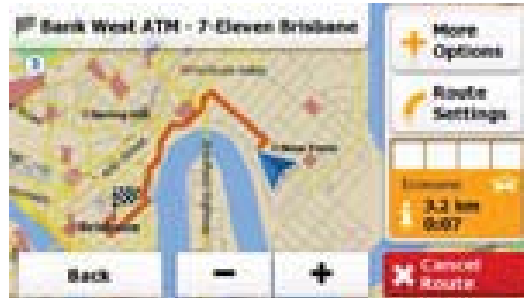

### 3.3 Checking the route parameters

You can check different parameters of the route recommended by the software.

1. If you are on the Map screen, tap  Menu to return to the Navigation menu.

2. In the Navigation menu, tap  .

The map showing the active route appears in top-down view facing North. Additional information and controls are displayed around the map.

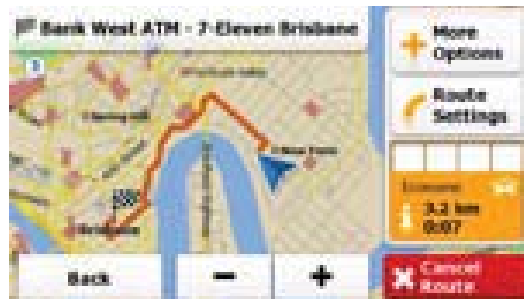





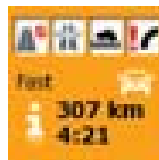

3. The following pieces of information are displayed:

- The active route is displayed in its full length on the map.
- The name or address of the destination is displayed at the top of the screen.
- You can find route information fields on the right with the following information:
  - Warning icons (if any). They provide extra information about your route (e.g. unpaved roads or toll roads to be taken).

- The route planning method (e.g. Fast).
- The symbol of the vehicle type used in route calculation.
- The total length of the route.
- The total time of the route.



4. You have the following options on this screen:

- Tap  for route alternatives, to run a simulation of the route, or to add the destination to the list of Favourite destinations.
- Tap  to change route parameters.
- Tap  to delete the active route.
- Tap  or  to scale the map.
- Tap  to return to the Navigation menu.

## 3.4 Modifying the route

When navigation is already started, there are several ways to modify the active route. The following sections show the different options.

### 3.4.1 Replacing the destination of the route

It is easy to replace the destination of the active route. Select a new destination as described before (starting at page 35), and the route will be automatically recalculated to lead to the new destination.

### 3.4.2 Setting a new starting position for the route

For normal navigation, all routes are planned from the current position. In order to check future routes, simulate them or see their length in time and distance, you can turn off the GPS receiver. Then you can set the starting point of the route to a different location than the current GPS position.

1. If you are on the Map screen, tap  **Menu** to return to the Navigation menu.
2. In the Navigation menu, tap  , and then  .





3. Tap  to scroll down and then  **Starting Position** .



4. Tap the large button in the centre of the screen. A screen similar to the address search screen is displayed.





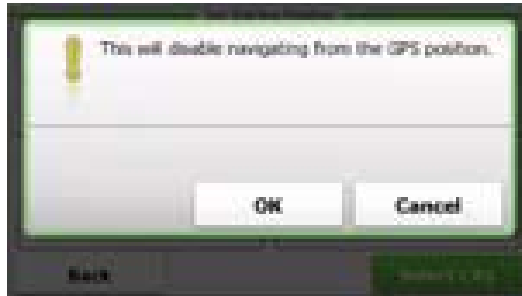

5. Select the address for the starting position, tap , and then tap  to confirm.

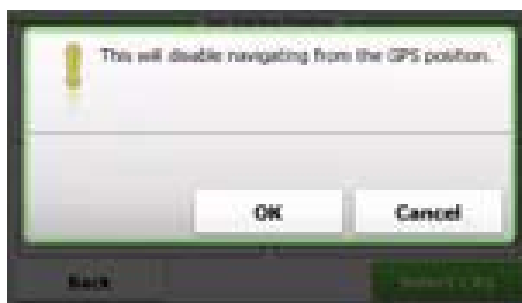

6. The map returns in grayscale (showing that there is no GPS reception). If an active route already existed, it is now recalculated starting from the selected location.



7. (optional) Tap  to modify the route or to check its parameters.

8. To return to normal navigation, tap .

### 3.4.3 Pausing the active route

You do not need to pause the active route: when you start driving again, the software restarts the voice instructions from your position.

### 3.4.4 Deleting the active route

To cancel the navigated route, do as follows:

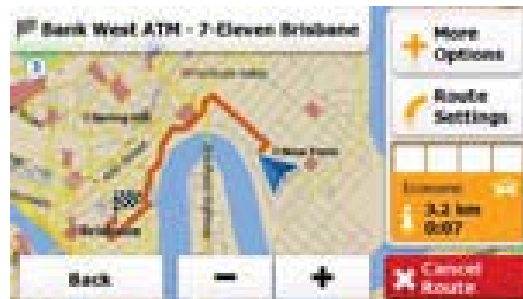

1. If you are on the Map screen, tap  to return to the Navigation menu.
2. In the Navigation menu, tap . The active route is displayed in its full length on the map together with additional information and controls.



3. Tap .
4. Tap  to confirm.

### 3.4.5 Changing the route planning method

To recalculate the active route with a different route planning method, do as follows. These changes can also be made in Settings (page 66).

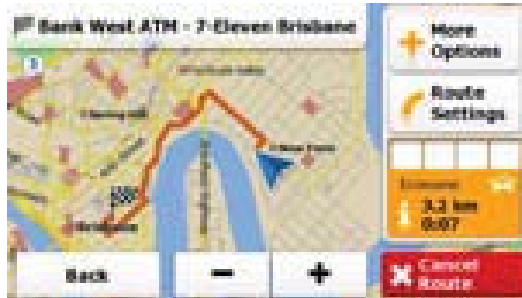

1. If you are on the Map screen, tap  to return to the Navigation menu.
2. In the Navigation menu, tap . The active route is displayed in its full length on the map together with additional information and controls.



3. Tap  .

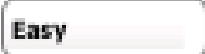

4. Tap  , and then tap one of the following:

-  - Gives a quick route if you can travel at or near the speed limit on all roads. Usually the best selection for fast and normal cars.
-  - Gives a short route. Usually practical for pedestrians, cyclists or slow vehicles.
-  - Combines the benefits of Fast and Short: The software calculates as if it were calculating the Fast route, but it takes other roads as well to save fuel.
-  - Results in a route with fewer turns and no difficult manoeuvres. With this option, you can make your software to take, for example, the motorway instead of series of smaller roads or streets.

5. The software recalculates the route with the selected route planning method. The orange line now shows the new recommended route.

### 3.4.6 Checking the route alternatives

Another way of recalculating the active route with a different route planning method, is to compare these alternatives. Do as follows:

1. If you are on the Map screen, tap  **Menu** to return to the Navigation menu.

2. In the Navigation menu, tap . The active route is displayed in its full length on the map together with additional information and controls.

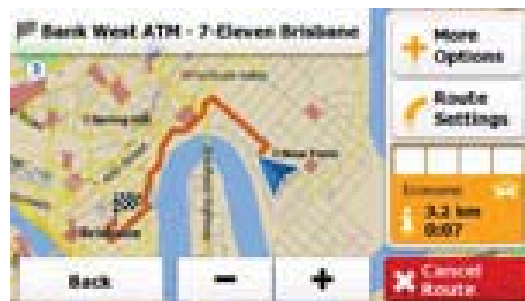

3. Tap  **More Options**.

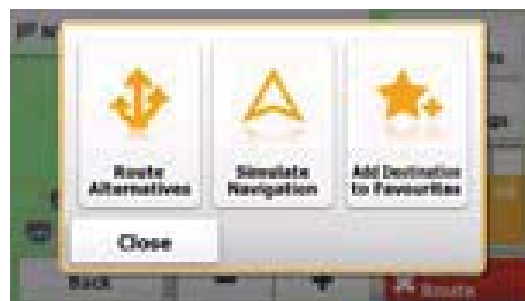

4. Tap . The map returns with the route fit to screen, and the total route distance together with the estimated duration of the route is displayed for each route planning method. Tap any of the methods, and the orange line on the map immediately shows the route with the selected route planning method.

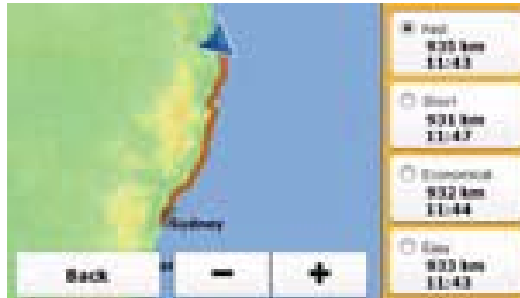

- - Gives a quick route if you can travel at or near the speed limit on all roads. Usually the best selection for fast and normal cars.
- - Gives a short route. Usually practical for pedestrians, cyclists or slow vehicles.
- - Combines the benefits of Fast and Short: The software calculates as if it were calculating the Fast route, but it takes other roads as well to save fuel.
- - Results in a route with fewer turns and no difficult manoeuvres. With this option, you can make your software to take, for example, the motorway instead of series of smaller roads or streets.

5. Tap  to return to the previous screen, and your software recalculates the route with the selected route planning method.

### 3.4.7 Changing the vehicle used in route planning

To recalculate the active route for a pedestrian or for a different vehicle, do as follows. These changes can also be made in Settings (page 92).

1. If you are on the Map screen, tap  to return to the Navigation menu.
2. In the Navigation menu, tap . The active route is displayed it in its full length on the map together with additional information and controls.

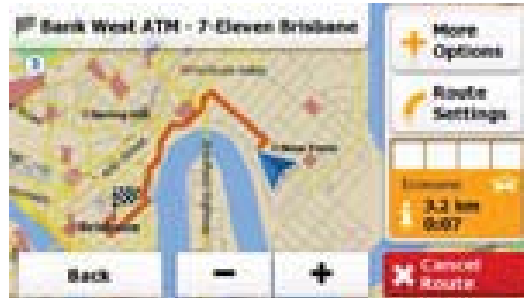

3. Tap  **Route Settings**.

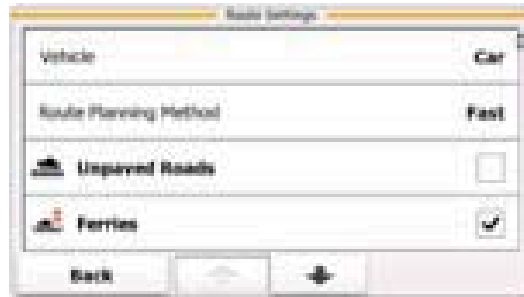

4. Tap , and then tap one of the following:

-  **Car**
-  **Pedestrian**
-  **Bicycle**
-  **Emergency**
-   **Bus**
-   **Taxi**

5. The software recalculates the route optimised for the new vehicle type. The orange line now shows the new recommended route.



**NOTE**

If you select  **Pedestrian** and you forget to change it back to a vehicle later, the software warns you when you travel with a speed that is too high for a pedestrian. You are allowed to switch back instantly to



**Car**

### 3.4.8 Changing the road types used in route planning

To recalculate the active route with different road type preferences, do as follows. These changes can also be made in Settings (page 92).

1. If you are on the Map screen, tap  **Menu** to return to the Navigation menu.



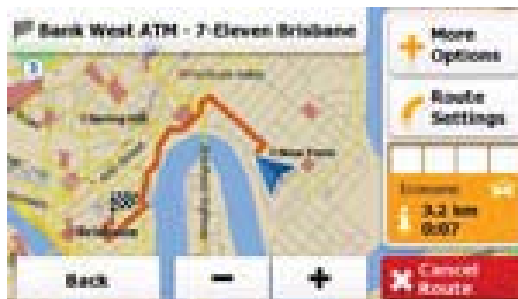



2. In the Navigation menu, tap  **My Route**. The active route is displayed in its full length on the map together with additional information and controls.



3. Tap  **Route Settings**.



4. Tap any of the listed road types to modify the route. If needed, tap  to list all road types. You have the following options (their order depends on the selected vehicle type):

-  **Period Charge** - Charge roads are pay roads where you can purchase a pass or vignette to use the road for a longer period of time. They can be enabled or disabled separately from toll roads.
  -  **Motorways** - You might need to avoid motorways when you are driving a slow car or you are towing another vehicle.
  -  **Unpaved Roads** - The software excludes unpaved roads by default: unpaved roads can be in a bad condition and usually you cannot reach the speed limit on them.
  -  **Ferries** - The software includes ferries in a planned route by default. However, a map does not necessarily contain information about the accessibility of temporary ferries. You might also need to pay a fare on ferries.
  -  **Per-use Toll** - The software includes toll roads (pay roads where there is a per-use charge) in the routes by default. If you disable toll roads, your software plans the best toll-free route.
5. Tap  to confirm the changes. The software recalculates the route. The orange line now shows the new recommended route.

### 3.5 Adding the destination of the route to Favourites

You can add the destination of the active route to Favourites, the list of frequently used destinations. Planning a route to one of the Favourite destinations is described on page 66.



1. If you are on the Map screen, tap  to return to the Navigation menu.
2. In the Navigation menu, tap . The active route is displayed in its full length on the map together with additional information and controls.

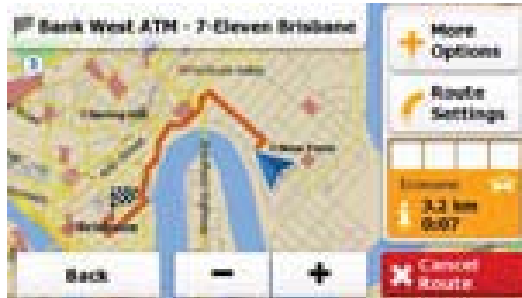

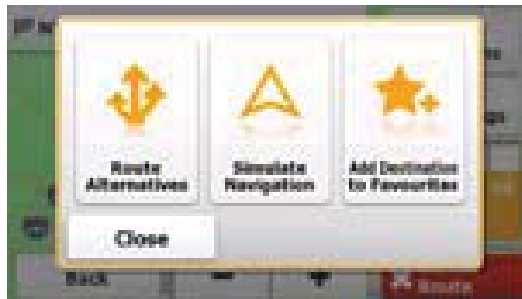

3. Tap  More Options .



4. Tap  . Using the keyboard, enter a name for the Favourite. Tap  to enter numbers or symbols.



5. Tap  to save the location as a new Favourite destination.

## 3.6 Watching the simulation of the route

You can run a simulated navigation that demonstrates the active route. Do as follows:

1. If you are on the Map screen, tap  **Menu** to return to the Navigation menu.
2. In the Navigation menu, tap . The active route is displayed in its full length on the map together with additional information and controls.

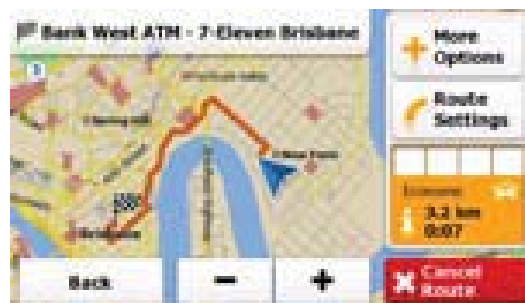

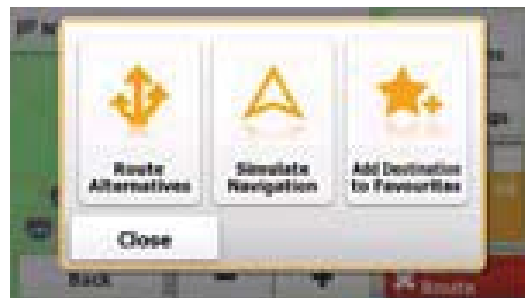

3. Tap .



4. Tap . The simulation starts from the starting point of the route, and using a realistic speed, it leads you through the whole recommended route.



You have the following controls during the simulation (the control buttons disappear after a few seconds but you can open them again if you tap the map):

-  : Jump to the next route event (manoeuvre).
-  : Pause the simulation.
-  : Jump to the previous route event (manoeuvre).

5. Tap  **STOP** to stop the simulation.

## 4 Reference Guide

---

On the following pages you will find the description of the different concepts and menu screens of the software.

### 4.1 Concepts

#### 4.1.1 Smart Zoom

Smart Zoom provides much more than just a usual automatic zoom feature:

- While following a route: when approaching a turn, it will zoom in and raise the view angle to let you easily recognise your manoeuvre at the next junction. If the next turn is at a distance, it will zoom out and lower the view angle to be flat so you can see the road in front of you.
- While driving without an active route: Smart Zoom will zoom in if you drive slowly and zoom out when you drive at high speed.

#### 4.1.2 Daytime and night colour themes

The software uses different colour themes during the day and during the night for both the map and the menu screens.

- Daytime colours are similar to paper road maps, and the menus are bright.
- The night colour themes use dark colours for large objects to keep the average brightness of the screen low.

The software offers different daytime and night colour profiles. It can also switch automatically between the daytime and the night schemes based on the current time and GPS position a few minutes before sunrise, when the sky has already turned bright, and a few minutes after sunset, before it becomes dark.

#### 4.1.3 Colour theme in tunnels

When entering a tunnel, the colours of the map change. All buildings disappear, large objects (such as surface waters or forests) and empty areas between roads

become black.

However, roads and streets keep their original colours from the daytime or night colour theme currently used.

After leaving the tunnel, the original colours return.







#### 4.1.4 Route calculation and recalculation

Your software calculates the route based on your preferences:





- Route planning methods:

- Fast
- Short
- Economical
- Easy

- Vehicle types:

-  Car
-  Pedestrian
-  Bicycle
-  Emergency
-  Bus
-  Taxi

- Road types used or avoided in route calculation:

-  Motorways
-  Period Change
-  Per-use Toll
-  Unpaved Roads
-  Ferries

Your software automatically recalculates the route if you deviate from the proposed itinerary.

For further information about Route settings, see page 92.

#### 4.1.5 Road Safety Cameras





The location of a Road Safety Camera is a special Place of Interest. These cannot be searched like other Places, and there is a special proximity warning only for cameras.

Is the software shipped with a built-in database of Road Safety Cameras?	Yes
Can Road Safety Camera locations be uploaded in a text file?	Yes
Can you save the Cursor as the location of a Road Safety Camera?	No

##### 4.1.5.1 Camera types

There are different types of Road Safety Cameras. For example:

Icon	Type	Description
	Fixed	Some speed cameras stand by the roadside, looking in one direction, measuring one or both directions of the traffic. They measure your current speed. The software warns you when you approach these speed cameras in the measured direction. If your speed exceeds the speed limit near the speed camera, a special warning sound is played.

	Mobile	<p>Some speed cameras are operated from vehicles. They do not always work and they are not set to check a preset speed limit. The warning is similar to fixed speed cameras, but as there is no speed limit given, only the proximity is announced.</p>
	Built-in	<p>Some speed cameras are built into traffic lights. They work like fixed speed cameras, but they are difficult to spot. The warning for proximity and speeding is the same as for the fixed speed cameras.</p>
	Section control	<p>These speed cameras work in pairs, and do not measure your current speed but your average speed between the two speed cameras. Both identify your car and record the exact time you pass them. They use the difference between the two points in time to calculate your average speed.</p> <p>The software warns you when you approach one of these speed cameras, but as you pass by, the warning stays on, and your average speed is measured until you reach another speed camera of this type. If your average speed exceeds the speed limit between the two speed cameras, you receive the same special warning sound as with the other speed camera types.</p> <p>In the rare case your software cannot register the moment you pass the second speed camera (for example, it is placed at the exit of a tunnel where GPS position is not yet available) the warning continues. Just tap the speed camera symbol displayed on the screen to stop the warning.</p> <p>Tap again to display the second route event with the possibility to open the Itinerary.</p>
	Red light	<p>These cameras check if you obey traffic lights. The warning is similar to mobile speed cameras: as there is no speed limit given, only the icon is displayed.</p>
	Rail Crossing	<p>This is not a camera but an alert point. The warning is similar to mobile speed cameras: as there is no speed limit given, only the warning icon is displayed. This warning icon may not be available for your region (ask your local dealer).</p>

### 4.1.5.2 Camera directions

A speed camera can measure the speed of one direction of the traffic, both directions, or even several directions in an intersection, when they are mounted on a rotating base. The same directions apply to red light cameras. The software warns you only if you drive in a measured or possibly measured direction.

### 4.1.6 Speed limit warning

Maps sometimes contain information about the speed limits of the road segments. This information may not be available for your region (ask your local dealer) or may not be fully correct for all roads on the map.



When you exceed the speed limit, a symbol with the speed limit appears in the corner of the map (for example: ).

Furthermore, you can turn on an audible warning: a voice message is played using the selected voice guidance profile when you exceed the speed limit. See page 94.

### 4.1.7 Battery and GPS position quality indicators

You can find useful information in the top corners of the high level menu screens (Navigation menu, Destination menu and 'More' menu).





The battery symbol in the top left corner, next to the current time shows information about the rechargeable battery of the device.

Icon	Description
	The battery is charging. The device runs on external power.
	The battery is not charging but it is full.
	The battery is not full but it still has enough capacity.



	You need to recharge the battery.
---	-----------------------------------

In the top right corner, the GPS reception quality icon shows the current accuracy of the position information.







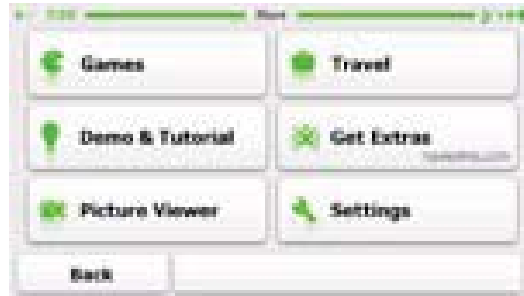

Icon	Description
	<p>The software has no connection to the GPS receiver: GPS navigation is not possible.</p> <p>Devices with a built-in GPS receiver are permanently connected. On such devices, the icon does not appear in normal circumstances.</p>
	<p>The software is connected to the GPS receiver, but the signal is too weak and the receiver cannot determine the GPS position.</p> <p>GPS navigation is not possible.</p>
	<p>Only a few satellites are received. Position information is available, but elevation (altitude) cannot be calculated.</p> <p>GPS navigation is possible, but the position error may be significant.</p>
	<p>Altitude information is available, the position is a 3D position. GPS navigation is possible.</p>

## 4.2 'More' menu

The 'More' menu provides you with various options and additional applications.

Tap the following buttons:  ,  .



Button	Description
 Games	<p>Play games. Tap any of the listed preinstalled games to try it in Demo mode, or tap  to get an activation key to play the selected game in its full version.</p> <p>Tap  <b>Get More</b> to download additional games from <a href="http://www.naviextras.com">www.naviextras.com</a>.</p>
 Travel	<p>Access travel applications: the unit converter, the clothing size converter, the list of international phone numbers and a calculator. First, you need to get an activation key for the application kit.</p>
 Demo & Tutorial	<p>Read the Tutorial to get instant understanding of the functions of your software, or run the Demo to watch sample route simulations to see how navigation works.</p>
 Picture Viewer	<p>Access the Picture Viewer application. This application is a free gift, but you need to get an activation key first.</p>
 Get Extras <small>www.naviextras.com</small>	<p>Get additional content, such as new maps or 3D landmarks; activate or download games and other applications.</p>
 Settings	<p>Fine-tune route planning options, change the Vehimarker, turn on or off warnings, start the Configuration wizard, etc. See the next chapter for details.</p>







## 4.3 Settings menu



You can configure the program settings, and modify the behaviour of the software.

Tap the following buttons:  **Menu** ,  **Home** ,  **Settings** .

The Settings menu has several options. Tap  or scroll the list with your finger to see the full list.









Button	Description
 <b>Route Settings</b>	These settings determine how routes will be calculated. Select the type of vehicle you are driving, the road types used in route planning, and the route planning method.
 <b>Sound and Warnings</b>	Adjust the sound volume, mute your device or enable warnings.
 <b>3D Vehicle Gallery</b>	Replace the current Vehimarker (position arrow) with a vehicle or pedestrian image.
 <b>Color Themes</b>	Set daytime and night colour themes for the map and the menus.
 <b>Starting Position</b>	Temporarily turn off the GPS receiver and set a different starting position for your route.
 <b>Regional</b>	Change the program language, the voice profile, time format and units or the keyboard language.
 <b>Content</b>	List all content items (maps, places of interests, landmarks, etc.) installed on your device. Both the active and the preinstalled inactive content items (activation needed at <a href="http://www.naviextras.com">www.naviextras.com</a> ) are listed.

 Start Configuration Wizard	Modify the basic software parameters set during the initial setup process. For details, see page 10.
 Reset to Defaults	Delete all saved data and reset all settings to their factory defaults.
 About	Read the Software and Database End User License Agreement, look up content licenses or check the unique identifier of the software.

### 4.3.1 Route settings

These settings determine how routes will be calculated.

Button	Description
	You can set the type of vehicle you will use to navigate the route. Based upon this setting, some of the road types can be excluded from the route, or some of the restrictions may not be taken into account in route calculation.
	The route calculation can be optimised for different situations and vehicle types by changing the planning method. See below for details.
	To let the route fit your needs, you can also set which road types are to be considered for or to be excluded from the route if possible.  Excluding a road type is a preference. It does not necessarily mean total prohibition. If your destination can only be accessed using some of the excluded road types, they will be used but only as much as necessary. In this case a warning icon will be shown on the Route Information screen, and the part of the route not matching your preference will be displayed in a different colour on the map.
 Motorways	You might need to avoid motorways when you are driving a slow car or you are towing another vehicle.



 Period Charge	<p>Charge roads are pay roads where you can purchase a pass or vignette to use the road for a longer period of time. They can be enabled or disabled separately from toll roads.</p>
 Per-use Toll	<p>The software includes toll roads (pay roads where there is a per-use charge) in the routes by default. If you disable toll roads, your software plans the best toll-free route.</p>
 Ferries	<p>The software includes ferries in a planned route by default. However, a map does not necessarily contain information about the accessibility of temporary ferries. You might also need to pay a fare on ferries.</p>
 Unpaved Roads	<p>The software excludes unpaved roads by default: unpaved roads can be in a bad condition and usually you cannot reach the speed limit on them.</p>

### Vehicle types:

-  Car
-  Pedestrian
-  Bicycle
-  Emergency
-  Bus
-  Taxi



### Route Planning Method types:

Option	Description
<input type="text" value="Fast"/>	<p>Gives a quick route if you can travel at or near the speed limit on all roads. Usually the best selection for fast and normal cars.</p>

	Gives a route that has the smallest total distance of all possible routes. Usually practical for pedestrians, cyclists or slow vehicles.
	Combines the benefits of Fast and Short: The software calculates as if it were calculating the Fast route, but it takes other roads as well to save fuel.
	Results in a route with fewer turns and no difficult manoeuvres. With this option, you can make your software to take, for example, the motorway instead of series of smaller roads or streets.

### 4.3.2 Sound settings

You can adjust the sounds of the software and enable some useful warnings.



Button	Description
Master Volume slider	Adjusts the sound volume of the device. All sounds of the application are affected.
	Use the switch to mute all sounds of the device and then to re-enable them again.
	Key sounds provide audible confirmation of either pressing hardware buttons or tapping the touch screen. The switch turns key sounds on or off.
	<p>Maps may contain information about the speed limits of the road segments. The software is able to warn you if you exceed the current limit. This information may not be available for your region (ask your local dealer), or may not be fully correct for all roads in the map.</p> <p>This setting lets you decide whether you wish to receive the audible warning (the visible warning is always on if you exceed the speed limit).</p>

Button	Description
	<p>This feature allows you to receive a warning when approaching a Road Safety Camera. You must ensure on your own liability that using this feature is legal in the country where you intend to use it. You have the following warnings:</p> <ul style="list-style-type: none"> <li>• Audible Warning: beeps play if you exceed the speed limit while approaching one of these cameras.</li> <li>• Visible Warning: the type of the camera and the monitored speed limit appear on the Map screen while you are approaching one of these cameras.</li> </ul> <p>This button is not displayed when GPS position is not available or if you are in certain countries where Road Safety Camera warning is prohibited. Even if the button is available, you are responsible for checking whether it is legal to use this feature at your location.</p>

### 4.3.3 3D vehicle gallery

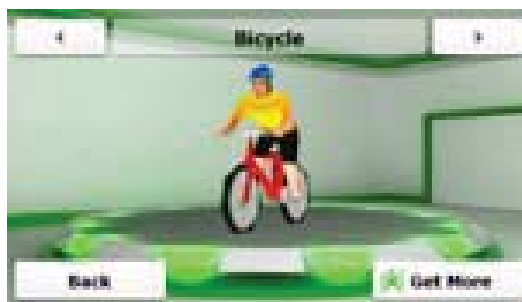
The current position is shown by a blue arrow on the map as a default. On this screen, you can select different 3D models to replace the default Vehimarker.



Button	Description
	<p>Select a 3D Vehimarker for navigation when the vehicle type used for route planning is set to  Car .</p>

Pedestrian	Select a 3D Vehimarker for navigation when the vehicle type used for route planning is set to  Pedestrian .
Other Vehicles	Select a 3D Vehimarker for all other vehicle types.



**TIP**

You can get more Vehimarkers at [www.naviextras.com](http://www.naviextras.com).

### 4.3.4 Colour themes

You can fine-tune the appearance of the Map screen and the menus. Choose suitable colour themes from the list for both daytime and night use. You can do it separately for the Map screen and all menu screens.



Tap any of the buttons to change the related colour theme, then select the new theme from the list.

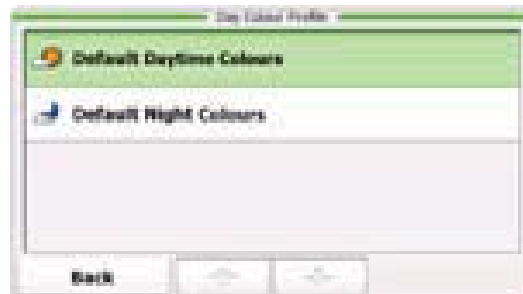







### 4.3.5 Set starting position

For normal navigation, all routes are planned from the current position. In order to check future routes, you can turn off the GPS receiver, and set the starting point of the route to a different location than the current GPS position.





The procedure is explained here: page 72.

### 4.3.6 Regional settings

These settings allow you to customise the application for your local language, measurement units, time and date settings and formats, as well as to choose the voice guidance profile you prefer.

Button	Description
	This button displays the current written language of the user interface. By tapping the button, you can select a new language from the list of available languages. The application will restart if you change this setting; you are asked to confirm this.
	This button shows the current voice guidance profile. By tapping the button, you can select a new profile from the list of available languages and speakers. Tap any of these to hear a sample voice prompt. Just tap OK when you have selected the new spoken language.
	See below.
	Select the virtual keyboard to be used when searching for an address or when entering a name to a Favourite destination. Various international keyboard layouts are available.

## Time Formats and Units:

Button	Description
	Use this feature to synchronise the time zone of the clock of your device to the time zone based on your current GPS position. This is useful if you travel abroad.
	Set time zone manually if you do not want to synchronise the time zone automatically. This allows you to use Auto Time Correction and apply a time zone offset to obtain the desired time.
	Select between 12 and 24 hours time display format.
	You can set the distance units to be used by the program. your software may not support all the listed units in some voice guidance languages. If you select a measurement unit not supported by the chosen voice guidance language, a warning message will appear.

### 4.3.7 Content

List all content items (maps, places of interests, landmarks, etc.) installed on your device. The list of the content categories is displayed first.

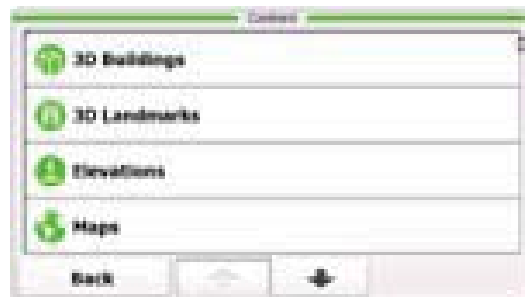

If needed, browse the list. Tap any of the categories to see its content.

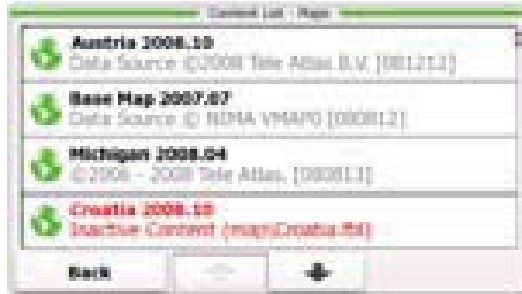

Both the active and the preinstalled inactive content items (activation needed at [www.naviextras.com](http://www.naviextras.com)) are listed. Inactive content items are displayed in red. Tap



in the 'More' menu to buy activation keys for the inactive content.

## 6 Glossary

---

### **2D/3D GPS reception**

The GPS receiver uses satellite signals to calculate its (your) position and needs at least four signals to give a three-dimensional position, including elevation. Because the satellites are moving and because objects can block the signals, your GPS device might not receive four signals. If three satellites are available, the receiver can calculate the horizontal GPS position but the accuracy is lower and the GPS device does not give you elevation data: only 2D reception is possible.

### **Active route**

The currently navigated route. Whenever the destination is set, the route is active until you delete it, reach your destination or you quit the software. See also: Route.

### **City Centre**

The city/town centre is not the geometric centre of the settlement but an arbitrary point the map creators have chosen. In towns and villages, it is usually the most important intersection; in larger cities, it is one of the important intersections.

### **Colour theme**

Your software comes with different colour themes for daytime or night use of the map and menu screens. Themes are custom graphic settings and they can have different colours for streets, blocks or surface waters in 2D and 3D modes, and they display shades or shadows in different ways in 3D mode.

One daytime scheme and one night scheme is always selected for the map and for the menus. The software uses them when it switches from day to night and back.

### **GPS accuracy**

Several factors have impact on the deviation between your real position and the one given by the GPS device. For example, signal delay in the ionosphere or reflecting objects near the GPS device have a different and varying impact on how accurately the GPS device can calculate your position.

## **Map**

The software works with digital maps which are not simply the computerised versions of traditional paper maps. Similarly to the paper road maps, the 2D mode of digital maps show you streets, roads, and elevation is also shown by colours.

In 3D mode, you can see the altitude differences, for example valleys and mountains, elevated roads, and in selected cities 3D landmarks and 3D buildings are also displayed.

You can use digital maps interactively: you can zoom in and out (increase or decrease the scale), you can tilt them up and down, and rotate them left and right. In GPS-supported navigation, digital maps facilitate route planning.

### **North-up map orientation**

In North-up mode the map is rotated so its top always faces North. This is the orientation for example in Find on Map. See also: Track-up map orientation.

### **Road Safety Camera**

A special Place of Interest type for speed cameras and red light cameras. Different data sources are available. You can configure the software to warn you when you approach one of these cameras.

Detecting the location of Road Safety Cameras is prohibited in certain countries. It is the sole responsibility of the driver to check whether this feature can be used during the trip.

### **Route**

A sequence of route events, i.e. manoeuvres (for example, turns and roundabouts) to reach the destination. The route contains one start point and one destination. The start point is the current (or last known) position by default. If you need to see a future route, the start point can be replaced with any other given point.

### **Track-up map orientation**

In Track-up mode the map is rotated so its top always points in the current driving

direction. This is the default orientation in 3D map view mode. See also: North-up map orientation.

## **Vehimarker**

The current position is shown with a blue arrow on the map by default. The direction of the blue arrow shows the current heading. This position marker can be replaced with different vehicle and pedestrian symbols. You can even specify different Vehimarkers for different route types (depending on which vehicle type is selected for route calculation).

# 7 End User Licence Agreement

---

## 1 The contracting parties

1.1 This Agreement has been entered into by and between Nav N Go Kft. (registered seat: 23 Bérc utca, H-1016 Budapest, Hungary; Company reg.no.: 01-09-891838) as Licensor (hereinafter: Licensor) and You as the User (hereinafter: User; the User and the Licensor jointly referred to as: Parties) in subject of the use of the software product specified in this Agreement.

## 2 Conclusion of the Agreement

2.1 The Parties hereby acknowledge that this Agreement shall be concluded by implicit conduct of the Parties without signing the Agreement.

2.2 The User hereby acknowledges that following the lawful acquisition of the software product constituting the object of this Agreement (Section 4), any degree of use, installation into a computer or other hardware, installation of such hardware into a vehicle, pressing of the “Accept” button displayed by the software during installation or use (hereinafter referred to as Use) shall mean that the User has accepted the terms and conditions of this Agreement as legally binding.

2.3 This Agreement shall by no means authorise use of the software product by those persons having unlawfully acquired the software product or having unlawfully installed it on a computer or in a vehicle.

## 3 Relevant laws and regulations

3.1 To all issues not regulated by this Agreement, the laws of the Republic of Hungary, with specific reference to Act IV of 1959 on the Civil Code and to Act LXXVI of 1999 on Copyrights shall apply.

3.2 The original language version of this Agreement is the Hungarian version. This Agreement has versions in other languages as well. In case of dispute the Hungarian version shall prevail.

## 4 Object of the Agreement

4.1 The object of this Agreement shall be the navigation guidance software product of Licensor (hereinafter referred to as the Software Product).

4.2 The Software Product shall include the operating computer program, its complete documentation, the map database pertaining thereto and any third-party content and services accessible through the Software Product (hereinafter: Database).

4.3 Any form of display, storage, coding, including printed, electronic or graphic display, storage, source or object code, or any other as yet undefined form of display, storage, or coding, or any medium thereof shall be deemed parts of the Software Product.

4.4 Error corrections, additions, updates used by the User following the conclusion of this Agreement shall also be deemed parts of the Software Product.

## 5 Rights under copyright

5.1 Unless otherwise provided by law or contractual provisions, the Licensor is the sole and exclusive owner of all material copyrights vested in the Software Product.

5.2 Copyrights extend to the whole Software Product and to its parts separately as well.

5.3 The owner(s) of the copyrights of the Database forming part of the Software Product is (are) the natural person(s) or corporate entity(ies) listed in the Appendix to this Agreement or in the "About" menu item of the operating computer programme (hereinafter referred to as Database Owner). The user's manual of the Software Product includes the name of the menu option where all the owners of the Database items are listed. The Licensor hereby states that it has obtained sufficient usage and representation rights from the Database owners in order to utilise the Database, to offer it for utilisation and to transfer it for utilisation as set forth in this Agreement.

5.4 Pursuant to this Agreement, all rights vested in the Software Product shall remain in the ownership of the Licensor, except for those to which the User is entitled under law or by virtue of this Agreement.

## 6 Rights of the User

6.1 The User is entitled to install the Software Product into one hardware device (desktop, handheld, portable computer, navigation device), and to run and use



one copy of the Software Product or a preinstalled copy of the Software Product thereon.

6.2 The User undertakes and accepts that the Software Product and/or its certain elements and/or contents provided by third parties may require separate action (registration/activation) within the time period specified in the Software product to achieve its partial or full functionality.

6.3 The User is entitled to make one backup copy of the Software Product. However, if the Software Product operates after installation without the use of the original media copy, then the original media copy shall be deemed to be a backup copy. In all other cases, the User is only entitled to use the backup copy if the original media copy of the Software Product has been ascertainably and unequivocally rendered unsuitable for its lawful and intended use.

## 7 Limitations of use

### 7.1 The User is not entitled

7.1.1 to duplicate the Software Product (to make a copy thereof);

7.1.2 to lease, rent or lend it or to transfer it to a third person for any reason;

7.1.3 to translate the Software Product (including translation (compilation) to other programming languages);

7.1.4 to decompile the Software Product;

7.1.5 to evade the protection of the Software Product or to modify, circumvent or obviate such protection through technological or by any other means;

7.1.6 to modify, extend, transform the Software Product (in whole or in part), to separate it into parts, combine it with other products, install it in other products, utilise it in other products, not even for the purpose of achieving interoperability with other devices;

7.1.7 apart from using the computer program, to obtain information from the Database as a part of the Software Product, to decompile the Database, to use, copy, modify, extend, transform the Database in whole or in part or the group of data stored therein, or to install it in other products or otherwise, utilise it in other products or to transfer it, not even with the aim of achieving interoperability with

other products.

7.2 The User acknowledges that the Software Product may prohibit or block partly or completely the use of the Software Product and/or its parts and/or third party contents if the separate action (activation/registration) as specified in Section 6 is not met within the time defined in the Software Product.

7.3 The User may only use the contents available through the Software Product and provided by third parties and the data received through the services provided by third parties for his/her own personal benefit and at his/her own risk. It is strictly prohibited to store, to transfer or to distribute these data or contents or to disclose them in full or in part to the public in any format or to download them from the product.

## 8 No warranty or limitation of responsibility

8.1 The Licensor hereby informs the User that although the greatest care was taken in producing the Software Product, given the nature of the Software Product and its technical limitations, the Licensor does not provide a warranty for the Software Product being completely error-free, and the Licensor is not bound by any contractual obligation whereby the Software Product obtained by the User should be completely error-free.

8.2 The Licensor does not warrant that the Software Product is suitable for any purpose defined either by the Licensor or the User, and does not warrant that the Software Product is capable of interoperating with any other system, device or product (e.g. software or hardware).

8.3 The Licensor does not assume any responsibility for damages incurred due to an error in the Software Product (including errors of the computer program, the documentation and the Database).

8.4 The Licensor does not assume any responsibility for damages incurred due to the Software Product not being applicable for any defined purpose, or due to the error or incompatibility of the Software Product with any other system, device or product (e.g. software or hardware).

8.5 The Licensor also draws the attention of the User to the fact that, when using the Software Product in any form of vehicle, observing the traffic regulations and rules (e.g. use of obligatory and/or reasonable and suitable security measures,

proper and generally expected care and attention in the given situation, and special care and attention required due to the use of the Software Product) is the exclusive responsibility of the User. The Licensor shall not assume any responsibility for any damages occurred in relation to use of the Software Product in a motor vehicle.

8.6 By concluding the Agreement, the User shall, in particular, acknowledge the information stated in Section 8 above.

## 9 Sanctions

9.1 The Licensor hereby informs the User that, if the Licensor finds its rights under the Copyright Act to be breached, the Licensor may

9.1.1 seek judicial recognition of this breach;

9.1.2 demand that the breach cease and order the person in breach to refrain from continuing such actions;

9.1.3 demand that the person under breach give proper compensation (even by way of publicity at the expense of the person in breach);

9.1.4 claim the return of the increase of assets due to the breach;

9.1.5 demand the cease of the wrongful action and, demand restitution to its state before the breach was committed at the expense of the person in breach, and may demand the destruction of instruments and materials used to commit the breach as well as of the products created by the breach;

9.1.6 claim for damages.

9.2 The Licensor hereby also informs the User that the breach of copyrights and related rights is a crime under Act IV of 1978 on the Hungarian Criminal Code, which may be sentenced of two years in prison in basic cases and up to eight years in prison in aggravated cases.

## 9.3 Contents and services provided by third parties

The Licensor hereby excludes any liability of its own for the Database in the Software Product and for any content or service provided by a third party by using the Database. The Licensor does not warrant the quality, suitability, accuracy, fitness for a specific purpose or territorial coverage of the product or service

or the availability of the service, and it specifically excludes any liability for the suspension of the service, and any damage arising in relation to the service or for complete cancellation of the service.

The relevant information and data in connection with the contents and services provided by third parties are available at [www.navngo.com](http://www.navngo.com). The User hereby acknowledges that the contents and services provided by third parties may only be used at the risk of the User and for the personal benefit of the User.

9.4 Contents and services provided by the Licensor or an agent of the Licensor  
The Licensor or a contractual partner may offer various products and services to the User through [www.naviextras.com](http://www.naviextras.com). The User may only use these services when the User has read and understood the relevant end user licence agreement(s) at [www.naviextras.com](http://www.naviextras.com) and the User is obliged to use the services in line with the terms and conditions thereof.

9.5 The parties hereby agree that - depending on the nature of the dispute - either the Pest Central District Court (Pesti Központi Kerületi Bíróság) or the Metropolitan Court of Budapest (Fővárosi Bíróság) will have exclusive jurisdiction to rule on any disputes arising in connection with this Agreement.

# UNIDEN TRAX5000 IN CAR NAVIGATION

---

## Limited One Year Warranty



### NOTE

Please keep your sales docket as it provides evidence of warranty.

**Important:** Evidence of original purchase is required for warranty service.

**Warrantor:** Uniden Australia Pty Limited A.B.N. 58 001 865 498  
Uniden New Zealand Limited

**Warranty is only valid in the original country of purchase.**

**ELEMENT OF WARRANTY:** Uniden warrants to the original retail owner for the duration of this warranty, its TRAX5000 (herein after referred to as the Product), to be free from defects in materials and craftsmanship with only the limitations or exclusions set out below.

**WARRANTY DURATION:** This warranty to the original retail owner only, shall terminate and be of no further effect ONE (1) year after the date of original retail sale. This warranty will be deemed invalid if the product is;

- (A) Damaged or not maintained as reasonable and necessary,
- (B) Modified, altered or used as part of any conversion kits, subassemblies, or any configurations not sold by Uniden,
- (C) Improperly installed,
- (D) Repaired by someone other than an authorized Uniden Repair Agent for a defect or malfunction covered by this warranty,
- (E) Used in conjunction with any equipment or parts or as part of a system not manufactured by Uniden, or
- (F) Where the Serial Number label of the product has been removed or damaged beyond recognition.

Warranty only valid in the country of original retail/sale.

**PARTS COVERED:** This warranty covers for one (1) year, the Product and included accessories.

**STATEMENT OF REMEDY:** In the event that the Product does not conform to this warranty at any time while this warranty is in effect, the warrantor at its discretion, will repair the defect or replace the Product and return it to you without charge for parts or service. This warranty does not provide for reimbursement or payment of incidental or consequential damages.

This EXPRESS WARRANTY is in addition to and does not in any way affect your rights under the TRADE PRACTICES ACT 1974 (Cth) (Australia) or the CONSUMER GUARANTEES ACT (New Zealand).

**PROCEDURE FOR OBTAINING PERFORMANCE OR WARRANTY:** In the event that the product does not conform to this warranty, the Product should be shipped or delivered, freight pre-paid, with evidence of original purchase (e.g. a copy of the sales docket), to the warrantor at:

**UNIDEN AUSTRALIA PTY  
LIMITED**

Service Division  
345 Princes Highway,  
Rockdale, NSW 2216  
Fax (02) 9599 3278

**[www.uniden.com.au](http://www.uniden.com.au)**

**UNIDEN NEW ZEALAND  
LIMITED**

Service Division  
150 Harris Road,  
East Tamaki, Manukau 2103  
Fax (09) 274 4253

**[www.uniden.co.nz](http://www.uniden.co.nz)**

# Notes

---

**THANK YOU FOR BUYING A UNIDEN PRODUCT.**

**Uniden<sup>®</sup>**

© 2009 Uniden Australia Pty Limited. Uniden New Zealand Ltd. Printed in PRC.