

Cerwin-Vega **mobile**

**STROKER S1000.1 / S2000.1
AMPLIFIER OWNERS MANUAL**

INTRODUCTION

Dear Cerwin-Vega Mobile Customer,

Thank you for making Cerwin-Vega Mobile your choice for high performance car audio products. At Cerwin-Vega Mobile, our goal is to produce products of unsurpassed quality. We believe you will not find a better value anywhere in the mobile audio environment.

To ensure that your new Cerwin-Vega Mobile amplifier provides years of enjoyment, you should consider having it installed by a professionally trained technician. They have the knowledge to make your new amplifier perform its very best.

WARNING: Prolonged exposure to sound pressure levels in excess of 100dB can cause permanent hearing loss. Cerwin-Vega Mobile amplifiers can exceed that level so please exercise restraint when listening and enjoying your new amplifier.

GENERAL PRECAUTIONS

- This unit is designed for negative ground 12V DC operation only.
- Total subwoofer impedance must not be less than 1 ohm.
- Avoid installing the unit where:
 - It would be subject to high temperatures, such as from direct sunlight or hot air from the heater.
 - It would be exposed to rain or moisture.
 - It would be subject to dust or dirt.
- Do not cover the unit with carpet or wires.
- Do not use the unit with a weak auto battery. Optimum performance depends on a normal battery supply voltage.
- For safety reasons, keep the volume of your car audio system moderate while driving your vehicle so that you can still hear normal traffic sounds outside your car.

MOUNTING PRECAUTIONS

Although Cerwin-Vega Mobile amplifiers incorporate heat sinks and protection circuits, mounting the amplifier in a tight space without any air movement can still damage internal circuitry over time. Choose a location that provides adequate ventilation around the amplifier. For easy system set-up, mount the amplifier so the side panel controls will be accessible after installation. In addition, observe the following precautions:

1. For the most efficient cooling, mount the amplifier so that air runs along the length of the fins rather than across them. Remember, any moving air across the amplifier will reduce heat.
2. Mount the amplifier on a solid surface. Avoid mounting to subwoofer enclosures or areas prone to vibration. Do not install the amplifier on plastic or other combustible materials.
3. Prior to mounting the amplifier, make sure not to cut or drill into the fuel tank, fuel lines, brake lines (under chassis) or electrical wiring.

WIRING PRECAUTIONS

1. Before installation, make sure the source unit power switch is in the OFF position.
2. Disconnect the negative (-) lead of the battery before making any power connections.
3. When making connections, be sure that each one is clean and secure. Insulate all of your connections. Failure to do so may damage your equipment.
4. A secure clean ground connection is critical to the performance of your amplifier. Connect the ground directly to the car chassis to minimize resistance and avoid any noise problems.
5. Add an external fuse on the amplifier's positive (+) power lead and connect it as close as possible to the vehicle's (+) battery terminal. Use a rating that equals the total current consumption at full output of all amplifiers in the system. This external fuse will protect the vehicle from short circuits that can cause a fire.

WIRING INSTRUCTIONS

Power Connection

The main power cable must be connected to the positive terminal of the vehicle battery to provide an adequate voltage source and minimize noise. There must be an inline fuse within 18 inches of the battery. Connecting the battery terminal lead to any other point will reduce the power output and may cause noise and distortion. Use only 4 gauge or larger wire for this lead and connect it to the (+) terminal of the battery with system fuse inline. Do not install the fuse in the fuse holder until the entire installation is completed.

Ground Connection

The ground terminal (GND) connection is also critical to the correct operation of the amplifier. Use a wire of the same gauge as the power connection and connect it between the ground terminal (GND) of the amplifier and a metal part of the vehicle close to the mounting location. This wire should be as short as possible and any paint or rust at the grounding point should be scraped away to provide a clean metal surface to which the end of the ground wire can be screwed or bolted.

Remote Turn-On Connection

The amplifier is turned on by applying +12V to the remote turn-on terminal (REM). The wire lead to this terminal should be connected to the remote lead from the car stereo which will provide the +12V only when the car stereo is turned on. If the car stereo does not provide a remote lead, the remote turn-on lead may be wired to an accessory terminal in the car's fuse block. This will turn the amplifier on and off with the ignition key, regardless of whether the car stereo is on or off.

Speaker Connections

Depending on the type and number of speakers used with the amplifier, wire them to the speaker terminals as per the appropriate wiring diagram (see below). For most applications 18 gauge wire is adequate for the speaker leads. For leads in excess of ten feet, 16 gauge wire is recommended. When wiring the speakers, pay careful attention to the polarity of the terminals on the speakers and make certain they correspond to the polarity on the amplifier. Do not ground any speaker leads to the chassis of the vehicle. Please see your authorized Cerwin-Vega Mobile dealer for specific wire recommendations.

INPUT CONNECTIONS

Most aftermarket source units will provide you with at least one pair of RCA outputs to provide a clean (low-level) input for your amplifier.

SET-UP INSTRUCTIONS

Input Level Control – The input level control is used to match the input level of your Cerwin-Vega Mobile amplifier with the output level of your source unit. Contrary to belief, turning the gain up does not give you any more power whatsoever. While it may appear to get louder when you turn your input sensitivity up, in reality, you are just taking away from your working range of volume on your source unit. To set the input level control properly, start with the input sensitivity all the way counter clockwise. Use a music source you are familiar with so you can tell when it starts to distort. Turn the volume on your source unit $\frac{3}{4}$ of the way to full volume, then slowly turn the input sensitivity clockwise until you can hear the music start to distort. Then, simply just turn back a bit counter clockwise until the distortion is no longer audible.

Crossover – Your Cerwin-Vega Mobile amplifier is equipped with a internal crossover for easy system set-up.

Low Pass Control – The amplifier will send frequencies below the cutoff point to pass through to your speakers.

Phase Control – Lets you control the output phase to your speakers (0/180 degrees).

Subsonic Filter – Controls the lowest frequency that will pass through to the speaker.

SPECIAL FUNCTIONAL FEATURES

RCA Output – For easy installation of multiple Cerwin-Vega Mobile amplifiers with a single RCA output from the source unit.

Wired Sub Level Control – Will allow you adjust the sub level from the front of the vehicle.

STATUS LED'S

Power - After the orderly connection of the three power terminals, the LED indicator shines green and goes out when the amplifier is switched off.

Protect - Your Cerwin-Vega Mobile amplifier is equipped with overload protection. Immediately upon overloading, (due to short circuit or extreme temperature) the protection is activated, and the red LED indicator is illuminated. The amplifier is now protected against damage. In case of thermal protection a short cooling time must be allowed after which the amplifier automatically resumes operation.

QUICK TROUBLESHOOTING GUIDE

No Power: Check that all the fuses are good. If so check to be sure that the remote turn on lead is properly connected, and that both Power and Ground connections are secure.

No Sound: Check to make sure input cables are installed properly. Also, check all speaker connections both at the amplifier and at the speaker itself.

No Sound / Red LED: Check that the speaker leads are not touching each other or the vehicle chassis. Be sure the total impedance of the speakers is not too low for the configuration.

Poor Sound Quality (Distortions): Check the amplifier Input Sensitivity setting. It may need to be turned down (counter clockwise). Check that the speaker wires are not touching the vehicle chassis. Verify that the vehicle battery is properly charged.

Weak Bass: One or more speaker connections (+) and (-) are reversed or are wired out of phase.

STRAPABILITY

Your new Cerwin-Vega Mobile amplifier has the unique ability to combine or “strap” either two S1000.1 or S2000.1 together to create one extremely powerful channel. You cannot strap an S1000.1 and S2000.1 together. You must connect two identical amplifiers only.

When you strap Cerwin-Vega Mobile Stroker amplifiers together, you get the added benefit of being able to use one remote level control to control both amplifiers. The following Diagrams provide several potential wiring options.

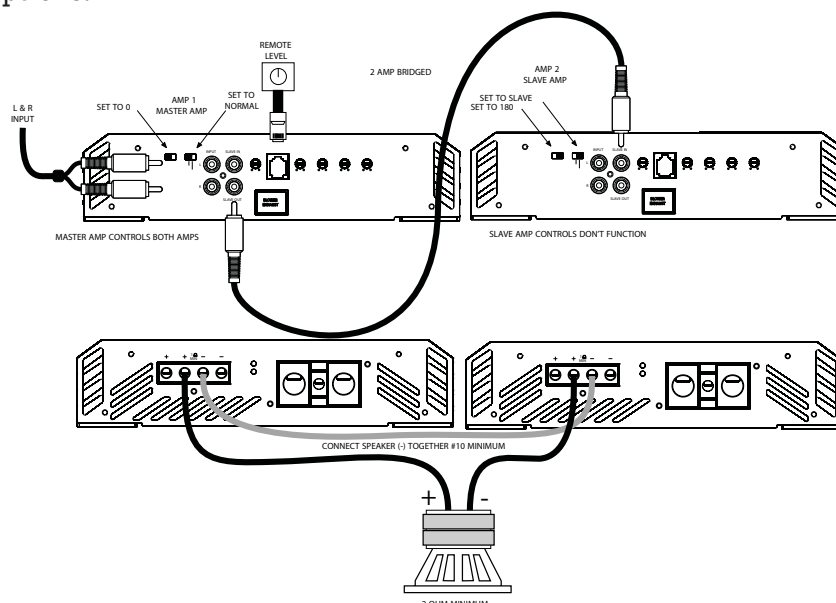

Master Amp Controlling 2 Bridged Sets

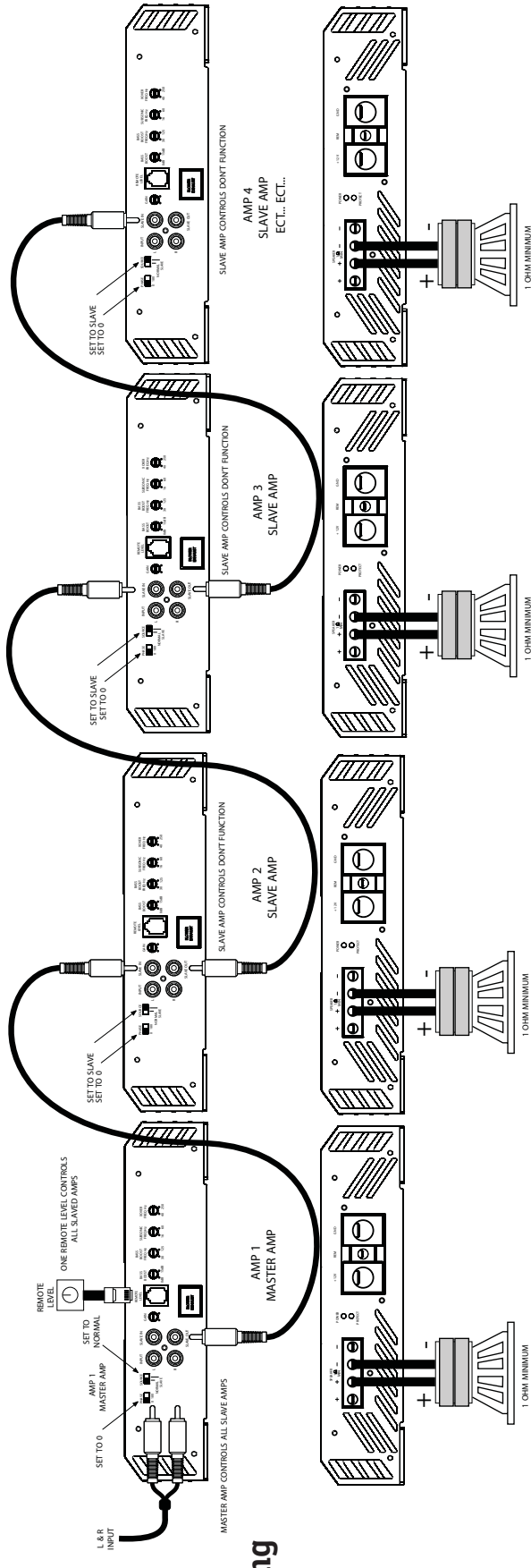
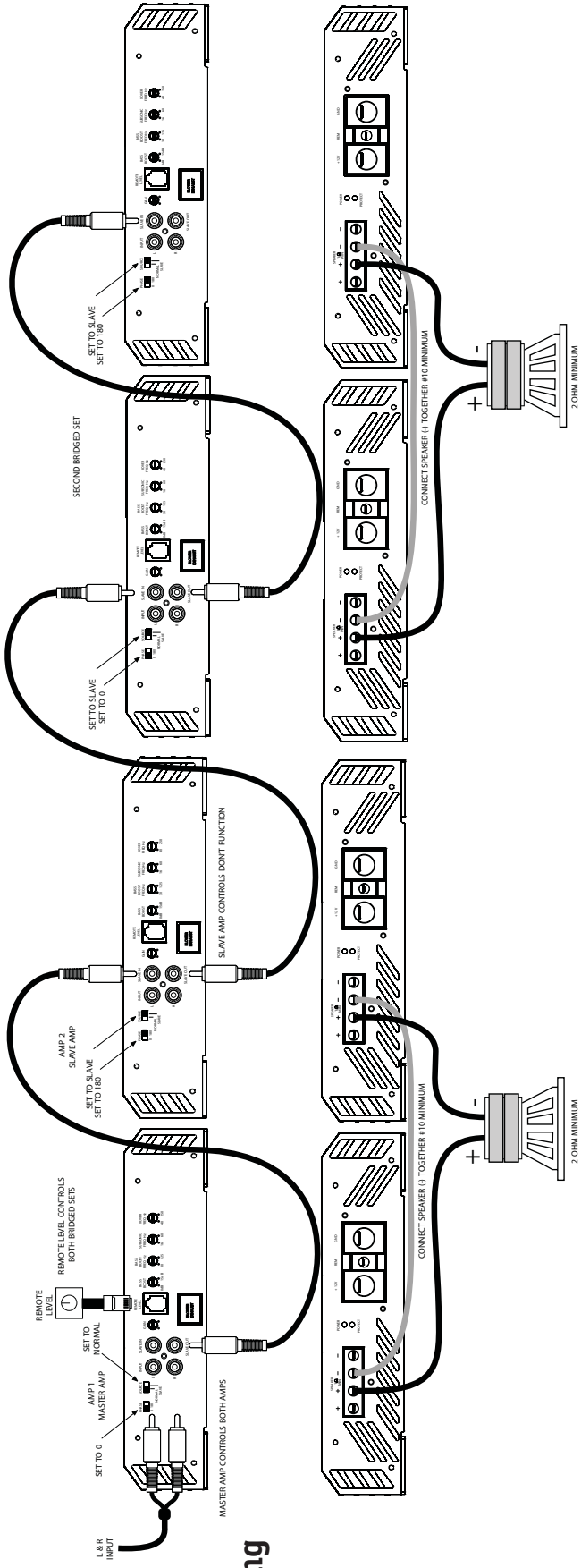

Master Amp Controlling Multiple Slave Amps

PRODUCT SPECIFICATIONS

	S1000.1	S2000.1
RMS Power Rating		
4 Ohm @14.4v	400 x 1	1000 x 1
2 Ohm @14.4v	750 x 1	1500 x 1
1 Ohm @14.4v	1000 x 1	2000 x 1
Power Supply	Full PWM	Full PWM
Topology	Class GH	Class GH
Frequency Response	20Hz-250Hz	20Hz-250Hz
Battery Voltage Range for Operation	10.8VDC - 15.0VDC	10.8VDC - 15.0VDC
S/N Ratio	>90dB	>90dB
Total Harmonic Distortion		
THD 4 Ohm	<0.05%	<0.05%
THD 2 Ohm	<0.05%	<0.05%
THD 1 Ohm	<0.08%	<0.08%
Input Sensitivity		
Low Input Level	100mV - 5V	100mV - 5V
Input Impedance		
Low Input Level	22K Ohm	22K Ohm
Crossover		
Variable Low-Pass	40-250Hz	40-250Hz

WARNING: YOU ARE REQUIRED TO USE AN OUTBOARD FUSE ON ALL STROKER MONO AMPLIFIERS. THERE ARE NO ONBOARD FUSES ON S1000.1 AND S2000.1.

- THE S1000.1 NEEDS AN INLINE 100 AMP FUSE AT BOTH THE BATTERY AND THE AMPLIFIER.
- THE S2000.1 NEEDS AN INLINE 200 AMP FUSE AT BOTH THE BATTERY AND THE AMPLIFIER.

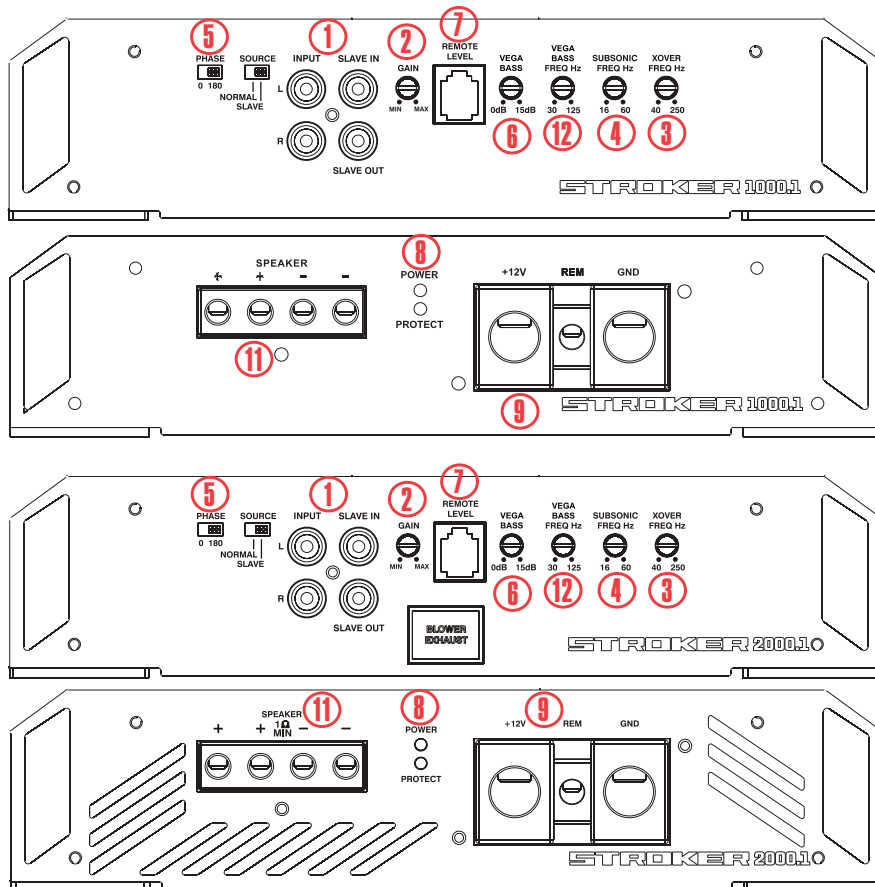

①	<u>RCA Input and Pass-Thru Output</u> - These RCA jacks allow for a normal Left and Right channel signal input. Simply connect to the source unit using RCA type audio cables, keeping them away from power wiring wherever possible. Mono models have a pass-through that can provide signal to another amplifier.
②	<u>Input Gain Adjustment</u> - This control matches the preamp stage of the Cerwin-Vega Mobile amplifier to your source unit. This is NOT a volume control. The range is between 100mV and 5V.
③	<u>Crossover Adjustment</u> - Use this adjustment to select the crossover point. Remember that your choice will be directed to High Pass or Low Pass depending upon the position of the adjacent switch. The range of adjustment is limited between 50-250 Hz.
④	<u>Sub-Sonic Adjustment</u> - This control allows you to adjust the “pass-band” for a true 3 way speaker system. This helps solve “standing wave” problems in-car (boomy bass), AND protects midrange/ mid-bass drivers at the same time.
⑤	<u>Phase Adjustment</u> - This control allows you to adjust the phase of your subwoofer in time with your mids and tweeters. 0 or 180 degrees of adjustment capability. This is EXTREMELY useful to get the best and MOST bass out of your system.
⑥	<u>Vega Bass</u> - This control adds 0 to +12dB of boost at 45Hz. Be cautious when adding boost to some subwoofer systems as they may not be able to handle the additional low frequency boost. In the OFF position, no bass boost is added.
⑦	<u>Remote Level Control</u> - This port is for the remote level control (included). The control is intended to allow the user to control the level of gain up to the maximum adjustment level set on the amplifier. The control does not add additional boost, it only attenuates the setting that is fixed at the amplifier’s control panel.
⑧	<u>Status LED’s</u> - These lights indicate when the amplifier is powered up normally and when there is a protection fault. See the “Troubleshooting” section for details on what these useful indicators can tell you if there’s a problem.
⑨	<u>Power Input Connections</u> - These connections are for input power, chassis ground, and remote turn-on. Use a minimum of 4 gauge wiring for power and ground connections. The terminals will handle up to 1/0 gauge wiring with no problem whatsoever. Be sure any wiring that passes through metal has a grommet!
⑩	<u>Power Fuses</u> - WARNING: You are required to use an outboard fuse on all Stroker mono amplifiers. There are no onboard fuses on S1000.1 and S2000.1. Also include a main fuse at the connection to the vehicle battery within 18 inches of the positive battery post. It is also important to upgrade the connection between the negative battery post and the chassis of the vehicle. This greatly reduces possibilities of weak electrical “links” in the circuit. The S1000.1 needs an inline 100 amp fuse at both the battery and the amplifier. The S2000.1 needs an inline 200 amp fuse at both the battery and the amplifier.
⑪	<u>Speaker Output Terminals</u> - Connect your speakers to these terminals. The S1000.1 and the S2000.1 are the only Cerwin-Vega Mobile amplifiers capable of driving a load as low as 1 ohm.
⑫	<u>Vega Bass Frequency EQ</u> - Use this adjustment to select the specific frequency that your Vega Bass will boost (30Hz - 125Hz)

Warranty

Cerwin-Vega Mobile warrants all amplifiers and speakers to be free of defects in material or workmanship for a period of 1 year.

Warranty Procedure:

Cerwin-Vega Mobile strongly suggests all warranty claims should be handled through an authorized dealer. Because of the technical nature of our products, performance problems can often be the result of improper usage or installation. An authorized retailer can help determine if this is the case and will save you the time of returning an item that is not actually defective.

For all VEGA subwoofer models the cone is to be removed from the basket as completely as possible. Cut the surround and then the spider. After this, the cone should lift out.

For VEGA coaxial models, the tweeter needs to be broken off and sent in with the cone.

All returns must have the serial number taped to the cone. The serial number can be found on the basket on all speakers and underneath the spider attached to the top of the magnet plate.

Please remove the sticker and tape it to the cone. This process will save everyone on shipping costs and allow us to check and replace speakers much faster.

For all VMAX models as well as all amplifier models, the defective unit needs to be returned. For speaker systems such as Vmax component models only return the defective part (i.e midbass, tweeter or crossover).

Shipping:

Once you have your RA number, ship your return to:

Cerwin-Vega Mobile
ATTN: Customer Service Dept.
6915 W. Frye Road
Chandler, AZ 85226

When we receive your return, we will process your order. Please make sure that you clearly mark the RA number on the outside of the box and on the shipping label.

If the RA number is not on the outside of box/label, it will be returned to sender!

Specifications subject to change without notice.



mobile

6915 W. Frye Road
Chandler, AZ 85226

480 838 9422 • 480 491 1201 [fax]

www.cerwinvegamobile.com